

FEATURES

- 10-Bit ADC with 9 μ s Conversion Time
- Four Single-Ended Analog Input Channels
- On-Chip Temperature Sensor
 - 55°C to +125°C
- On-Chip Track/Hold
- On-Chip Reference (2.5 V \pm 1%)
- Over-Temperature Indicator
- Automatic Power-Down at the End of a Conversion
- Wide Operating Supply Range
 - 2.7 V to 5.5 V
- Flexible Serial Interface
 - Three-Wire Operation, Allows Easy Interfacing to Most Microcontrollers—Intel 8051, Motorola SPI, National Semiconductor's MICRO-WIRE
- Low Power Operation
 - Normal Operation (6 mW max, V_{DD} = 3 V)
 - Automatic Power-Down (60 μ W, 1 kSPS, V_{DD} = 3 V)
 - Power-Down Mode (1 μ A max)

APPLICATIONS

- Data Acquisition Systems with Ambient Temperature Monitoring
- Industrial Process Control
- Automotive
- Battery Charging Applications

GENERAL DESCRIPTION

The AD7817 is a 10-bit, 4-channel A/D converter with on-chip temperature sensor that can operate from a single 2.7 V to 5.5 V power supply. The device contains a 9 μ s successive-approximation converter based around a capacitor DAC, a 5-channel multiplexer, an on-chip temperature sensor, an on-chip clock oscillator, an on-chip track/hold, and an on-chip reference (2.5 V).

The on-chip temperature sensor can be accessed via multiplexer Channel 0. When the multiplexer Channel 0 is selected and a conversion is initiated the resulting ADC code at the end of the conversion gives a measurement of the ambient temperature ($\pm 1^\circ\text{C}$ @ +25°C). See Measuring Temperature section of the data sheet.

The AD7817 has a flexible serial interface which allows easy interfacing to most microcontrollers and DSPs. The interface is compatible with the Intel 8051, Motorola SPI and QSPI

REV. 0

Information furnished by Analog Devices is believed to be accurate and reliable. However, no responsibility is assumed by Analog Devices for its use, nor for any infringements of patents or other rights of third parties which may result from its use. No license is granted by implication or otherwise under any patent or patent rights of Analog Devices.

FUNCTIONAL BLOCK DIAGRAM

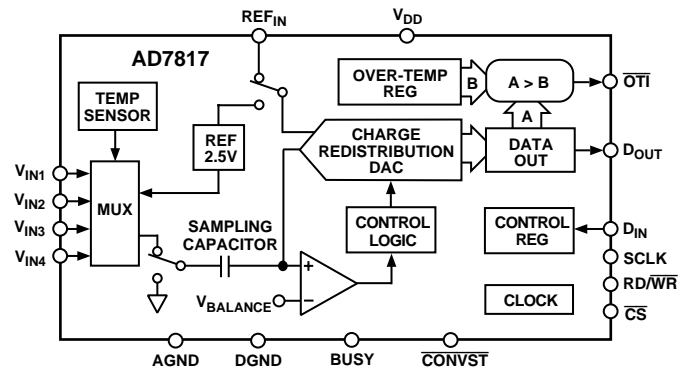

protocols and National Semiconductor's MICRO-WIRE protocol. For more information refer to the Serial Interface section of this data sheet.

The AD7817 is powered down by leaving the $\overline{\text{CONVST}}$ signal low at the end of a conversion—see Operating Modes section of the data sheet. This feature can be used to enable an automatic power-down between conversion. This significantly improves the power performance of the AD7817 at slower throughput rates—See Power vs. Throughput section.

The part is available in a narrow body 0.15" 16-lead small outline IC (SOIC) and in a 16-lead, tiny shrink small outline package (TSSOP).

PRODUCT HIGHLIGHTS

1. The AD7817 has an on-chip temperature sensor which allows an accurate measurement of the ambient temperature ($\pm 1^\circ\text{C}$ @ +25°C, $\pm 2^\circ\text{C}$ over temperature) to be made. The measurable temperature range is -55°C to +125°C. An over-temperature indicator is implemented by carrying out a digital comparison of the ADC code for Channel 0 (temperature sensor) with the contents of the on-chip over-temperature register.
2. The AD7817 offers a space saving 10-bit A/D solution with four external voltage input channels, an on-chip temperature sensor, an on-chip reference and clock oscillator.
3. The automatic power-down feature enables the AD7817 to achieve superior power performance at slower throughput rates, e.g., 60 μ W at 1 kSPS throughput rate.

AD7817–SPECIFICATIONS¹ ($V_{DD} = +2.7\text{ V to }+5.5\text{ V}$, $GND = 0\text{ V}$, $REF_{IN} = +2.5\text{ V}$)

Parameter	A Version	B Version	S Version	Units	Test Conditions/Comments
DYNAMIC PERFORMANCE					
Signal to (Noise+Distortion) Ratio ²	58	58	58	dB min	Sample Rate = 100 kSPS, Any Channel, $f_{IN} = 20\text{ kHz}$
Total Harmonic Distortion ²	-65	-65	-65	dB max	-75 dB typ
Peak Harmonic or Spurious Noise ²	-65	-65	-65	dB typ	-75 dB typ
Intermodulation Distortion ²					$f_a = 19.9\text{ kHz}$, $f_b = 20.1\text{ kHz}$
Second Order Terms	-67	-67	-67	dB typ	
Third Order Terms	-67	-67	-67	dB typ	
Channel-to-Channel Isolation ²	-80	-80	-80	dB typ	$f_{IN} = 20\text{ kHz}$
DC ACCURACY					
Resolution	10	10	10	Bits	Any Channel
Minimum Resolution for Which No Missing Codes Are Guaranteed	10	10	10	Bits	
Relative Accuracy ²	±1	±1	±1	LSB max	
Differential Nonlinearity ²	±1	±1	±1	LSB max	
Gain Error ²	±2	±2	±2	LSB max	External Reference
	±10	±10	+20/-10	LSB max	Internal Reference
Gain Error Match ²	±1/2	±1/2	±1/2	LSB max	
Offset Error ²	±2	±2	±2	LSB max	
Offset Error Match	±1/2	±1/2	±1/2	LSB max	
ANALOG INPUTS					
Input Voltage Range	V_{REF} 0	V_{REF} 0	V_{REF} 0	V max V min	
Input Leakage Current ³	±1	±1	±1	µA max	
Input Capacitance	10	10	10	pF max	
TEMPERATURE SENSOR¹					
Measurement Error					External Reference $V_{REF} = 2.5\text{ V}$
Ambient Temperature +25°C	±2	±1	±2	°C max	
T_{MIN} to T_{MAX}	±3	±2	±3	°C max	
Measurement Error ⁴					On-Chip Reference
Ambient Temperature +25°C	±2.25	±2.25	±2.25	°C max	
T_{MIN} to T_{MAX}	±3	±3	±6	°C max	
Temperature Resolution	1/4	1/4	1/4	°C/LSB	
REFERENCE INPUT⁴					
REF_{IN} Input Voltage Range ⁴	2.625 2.375	2.625 2.375	2.625 2.375	V max V min	2.5 V + 5% 2.5 V - 5%
Input Impedance	40	40	40	kΩ min	
Input Capacitance	10	10	10	pF max	
ON-CHIP REFERENCE					
Reference Error ⁵	±25	±25	±50	mV max	Nominal 2.5 V
Temperature Coefficient ⁵	80	80	150	ppm/°C typ	
LOGIC INPUTS⁶					
Input High Voltage, V_{INH}	2.4	2.4	2.4	V min	$V_{DD} = 5\text{ V} \pm 10\%$
Input Low Voltage, V_{INL}	0.8	0.8	0.8	V max	$V_{DD} = 5\text{ V} \pm 10\%$
Input High Voltage, V_{INH}	2	2	2	V min	$V_{DD} = 3\text{ V} \pm 10\%$
Input Low Voltage, V_{INL}	0.4	0.4	0.4	V max	$V_{DD} = 3\text{ V} \pm 10\%$
Input Current, I_{IN}	±3	±3	±3	µA max	Typically 10 nA, $V_{IN} = 0\text{ V to }V_{DD}$
Input Capacitance, C_{IN}	10	10	10	pF max	
LOGIC OUTPUTS⁶					
Output High Voltage, V_{OH}	4 2.4	4 2.4	4 2.4	V min V min	$I_{SOURCE} = 200\text{ µA}$ $V_{DD} = 5\text{ V} \pm 10\%$ $V_{DD} = 3\text{ V} \pm 10\%$
Output Low Voltage, V_{OL}	0.4 0.2	0.4 0.2	0.4 0.2	V max V min	$I_{SINK} = 200\text{ µA}$ $V_{DD} = 5\text{ V} \pm 10\%$ $V_{DD} = 3\text{ V} \pm 10\%$
High Impedance Leakage Current	±1	±1	±1	µA max	
High Impedance Capacitance	15	15	15	pF max	

Parameter	A Version	B Version	S Version	Units	Test Conditions/Comments
CONVERSION RATE					
Track/Hold Acquisition Time	400	400	400	ns max	Source Impedance < 10 Ω
Conversion Time					
Temperature Sensor	27	27	27	μ s max	
Channels 1 to 4	9	9	9	μ s max	
POWER REQUIREMENTS					
V_{DD}	+5.5	+5.5	+5.5	V max	For Specified Performance
	+2.7	+2.7	+2.7	V min	
I_{DD}					Logic Inputs = 0 V or V_{DD}
Normal Operation	2	2	2	mA max	1.6 mA Typically
Using External Reference ⁵	1.75	1.75	1.75	mA max	2.5 V External Reference Connected
Power-Down	1	1	2	μ A max	50 nA Typically
Auto Power-Down Mode					$V_{DD} = 3$ V
10 SPS Throughput Rate	6	6	6	μ W typ	See Power vs. Throughput for
1 kSPS Throughput Rate	60	60	60	μ W typ	Description Power Dissipation in
10 kSPS Throughput Rate	600	600	600	μ W typ	Auto Power-Down Mode
Power-Down	3	3	6	μ W max	Typically 0.15 μ W

NOTES

¹A Version -40°C to $+85^{\circ}\text{C}$, B Version -40°C to $+85^{\circ}\text{C}$ and S Version -55°C to $+125^{\circ}\text{C}$.

²See Terminology.

³Refers to the input current when the part is not converting. Primarily due to reverse leakage current in the ESD protection diodes.

⁴The accuracy of the temperature sensor is affected by reference tolerance. The relationship between the two is explained in the Temperature Sensor section of the data sheet.

⁵On-Chip reference shuts down when external reference is applied.

⁶Sample tested during initial release and after any redesign or process change that may affect this parameter.

Specifications subject to change without notice.

ORDERING GUIDE

Model	Temperature Error	Package Description	Package Options
AD7817AR	$\pm 2^{\circ}\text{C}$	16-Lead Narrow Body SOIC	R-16A
AD7817BR	$\pm 1^{\circ}\text{C}$	16-Lead Narrow Body SOIC	R-16A
AD7817SR	$\pm 2^{\circ}\text{C}$	16-Lead Narrow Body SOIC	R-16A
AD7817ARU	$\pm 2^{\circ}\text{C}$	16-Lead Thin Shrink Small Outline Package (TSSOP)	RU-16

AD7817

TIMING CHARACTERISTICS^{1, 2} ($V_{DD} = +2.7\text{ V to } +5.5\text{ V}$, $GND = 0\text{ V}$, $REF_{IN} = +2.5\text{ V}$. All Specifications T_{MIN} to T_{MAX} unless otherwise noted.)

Parameter	A, B, S Versions	Units	Test Conditions/Comments
$t_{POWER-UP}$	2	$\mu\text{s max}$	Power-Up Time from Rising Edge of \overline{CONVST}
t_{1a}	9	$\mu\text{s max}$	Conversion Time Channels 1 to 4
t_{1b}	27	$\mu\text{s max}$	Conversion Time Temperature Sensor
t_2	20	ns min	\overline{CONVST} Pulsewidth
t_3	50	ns max	\overline{CONVST} Falling Edge to $BUSY$ Rising Edge
t_4	0	ns min	\overline{CS} Falling Edge to RD/\overline{WR} Falling Edge Setup Time
t_5	0	ns min	RD/\overline{WR} Falling Edge to $SCLK$ Falling Edge Setup
t_6	10	ns min	DIN Setup Time Before $SCLK$ Rising Edge
t_7	10	ns min	DIN Hold Time After $SCLK$ Rising Edge
t_8	40	ns min	$SCLK$ Low Pulsewidth
t_9	40	ns min	$SCLK$ High Pulsewidth
t_{10}	0	ns min	\overline{CS} Falling Edge to RD/\overline{WR} Rising Edge Setup Time
t_{11}	0	ns min	RD/\overline{WR} Rising Edge to $SCLK$ Falling Edge Setup Time
t_{12}^3	20	ns max	$DOUT$ Access Time After RD/\overline{WR} Rising Edge
t_{13}^3	20	ns max	$DOUT$ Access Time After $SCLK$ Falling Edge
$t_{14a}^{3, 4}$	30	ns max	$DOUT$ Bus Relinquish Time After Falling Edge of RD/\overline{WR}
$t_{14b}^{3, 4}$	30	ns max	$DOUT$ Bus Relinquish Time After Rising Edge of \overline{CS}
t_{15}	150	ns max	$BUSY$ Falling Edge to \overline{OTI} Falling Edge
t_{16}	40	ns min	RD/\overline{WR} Rising Edge to \overline{OTI} Rising Edge
t_{17}	400	ns min	$SCLK$ Rising Edge to \overline{CONVST} Falling Edge (Acquisition Time of T/H).

NOTES

¹Sample tested during initial release and after any redesign or process change that may affect this parameter. All input signals are measured with $t_r = t_f = 1\text{ ns}$ (10% to 90% of +5 V) and timed from a voltage level of +1.6 V.

²See Figures 14, 15 and 18.

³These figures are measured with the load circuit of Figure 1. They are defined as the time required for D_{OUT} to cross 0.8 V or 2.4 V for $V_{DD} = 5\text{ V} \pm 10\%$ and 0.4 V or 2 V for $V_{DD} = 3\text{ V} \pm 10\%$, as quoted on the specifications page of this data sheet.

⁴These times are derived from the measured time taken by the data outputs to change 0.5 V when loaded with the circuit of Figure 1. The measured number is then extrapolated back to remove the effects of charging or discharging the 50 pF capacitor. This means that the times quoted in the timing characteristics are the true bus relinquish times of the part and as such are independent of external bus loading capacitances.

Specifications subject to change without notice.

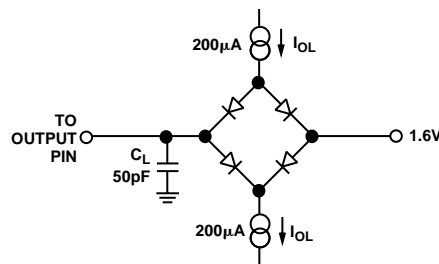

Figure 1. Load Circuit for Access Time and Bus Relinquish Time

CAUTION

ESD (electrostatic discharge) sensitive device. Electrostatic charges as high as 4000 V readily accumulate on the human body and test equipment and can discharge without detection. Although the AD7817 features proprietary ESD protection circuitry, permanent damage may occur on devices subjected to high energy electrostatic discharges. Therefore, proper ESD precautions are recommended to avoid performance degradation or loss of functionality.



PIN FUNCTION DESCRIPTIONS

Pin	Mnemonic	Description
1	$\overline{\text{CONVST}}$	This is a logic input signal; the convert start signal. A 10-bit analog-to-digital conversion is initiated on the falling edge of the this signal. The falling edge of this signal places the track/hold in hold mode. The track/hold goes into track mode again at the end of the conversion. The state of the $\overline{\text{CONVST}}$ signal is checked at the end of a conversion. If it is logic low, then the AD7817 will power down—see Operating Mode section.
2	BUSY	This is a logic output. The busy signal is logic high during a temperature or voltage A/D conversion. The signal can be used to interrupt a microcontroller when a conversion has finished.
3	$\overline{\text{OTI}}$	This is a logic output. The Over-Temperature Indicator ($\overline{\text{OTI}}$) is set logic low if the result of a conversion on Channel 0 (temperature sensor) is greater that an eight-bit word in the Over-Temperature Register (OTR). The signal is reset at the end of a serial read operation; i.e., a rising RD/ $\overline{\text{WR}}$ edge when $\overline{\text{CS}}$ is low.
4	$\overline{\text{CS}}$	This is a logic input signal. The chip select signal is used to enable the serial port of the AD7817. This is necessary if the AD7817 is sharing the serial bus with more than one device.
5	AGND	Analog Ground. Ground reference for track/hold, comparator and capacitor DAC.
6	REF _{IN}	This is an analog input. An external 2.5 V reference can be connected to the AD7817 at this pin. To enable the on-chip reference, the REF _{IN} pin should be tied to AGND. If an external reference is connected to the AD7817, the internal reference will shut down.
7–10	V _{IN4} to V _{IN1}	Analog input channels. The AD7817 has four analog input channels. The input channels are single-ended with respect to AGND (analog ground). The input channels can convert voltage signals in the range 0 V to V _{REF} . A channel is selected by writing to the Address register of the AD7817—See Control Byte section.
11	V _{DD}	Positive Supply Voltage, +2.7 V to +5.5 V.
12	DGND	Digital Ground. Ground reference for digital circuitry.
13	D _{OUT}	This is a logic output with a high impedance state. Data is clocked out of the AD7817 serial port at this pin. This output goes into a high impedance state on the falling edge of RD/ $\overline{\text{WR}}$ or on the rising edge of the $\overline{\text{CS}}$ signal whichever occurs first.
14	D _{IN}	This is a logic input. Data is clocked into the AD7817 at this pin.
15	SCLK	This the clock input for the serial port. The serial clock is used to clock data into and out of the AD7817. Data is clocked out on the falling edge and clocked in on the rising edge.
16	RD/ $\overline{\text{WR}}$	This is a logic input signal. The read/write signal is used to indicate to the AD7817 whether the data transfer operation is a read or a write. The RD/ $\overline{\text{WR}}$ should be set logic high for a read operation and logic low for a write operation.

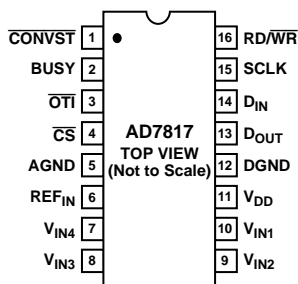
PIN CONFIGURATION
SOIC/TSSOP

AD7817

TERMINOLOGY

Signal to (Noise + Distortion) Ratio

This is the measured ratio of signal to (noise + distortion) at the output of the A/D converter. The signal is the rms amplitude of the fundamental. Noise is the rms sum of all nonfundamental signals up to half the sampling frequency ($f_s/2$), excluding dc. The ratio is dependent upon the number of quantization levels in the digitization process; the more levels, the smaller the quantization noise. The theoretical signal to (noise + distortion) ratio for an ideal N-bit converter with a sine wave input is given by:

$$\text{Signal to (Noise + Distortion)} = (6.02N + 1.76) \text{ dB}$$

Thus for a 10-bit converter, this is 62 dB.

Total Harmonic Distortion

Total harmonic distortion (THD) is the ratio of the rms sum of harmonics to the fundamental. For the AD7891 it is defined as:

$$\text{THD (dB)} = 20 \log \frac{\sqrt{V_2^2 + V_3^2 + V_4^2 + V_5^2 + V_6^2}}{V_1}$$

where V_1 is the rms amplitude of the fundamental and V_2 , V_3 , V_4 , V_5 and V_6 are the rms amplitudes of the second through the sixth harmonics.

Peak Harmonic or Spurious Noise

Peak harmonic or spurious noise is defined as the ratio of the rms value of the next largest component in the ADC output spectrum (up to $f_s/2$ and excluding dc) to the rms value of the fundamental. Normally, the value of this specification is determined by the largest harmonic in the spectrum, but for parts where the harmonics are buried in the noise floor, it will be a noise peak.

Intermodulation Distortion

With inputs consisting of sine waves at two frequencies, f_a and f_b , any active device with nonlinearities will create distortion products at sum and difference frequencies of $m f_a \pm n f_b$ where $m, n = 0, 1, 2, 3$, etc. Intermodulation terms are those for which neither m nor n are equal to zero. For example, the second order terms include $(f_a + f_b)$ and $(f_a - f_b)$, while the third order terms include $(2f_a + f_b)$, $(2f_a - f_b)$, $(f_a + 2f_b)$ and $(f_a - 2f_b)$.

The AD7817 is tested using the CCIF standard where two input frequencies near the top end of the input bandwidth are used. In this case, the second and third order terms are of different significance. The second order terms are usually distanced in frequency from the original sine waves while the third order terms are usually at a frequency close to the input frequencies. As a result, the second and third order terms are specified separately. The calculation of the intermodulation distortion is as per the THD specification where it is the ratio of the rms sum of the individual distortion products to the rms amplitude of the fundamental expressed in dBs.

Channel-to-Channel Isolation

Channel-to-channel isolation is a measure of the level of crosstalk between channels. It is measured by applying a full-scale 20 kHz sine wave signal to one input channel and determining how much that signal is attenuated in each of the other channels. The figure given is the worst case across all four channels.

Relative Accuracy

Relative accuracy or endpoint nonlinearity is the maximum deviation from a straight line passing through the endpoints of the ADC transfer function.

Differential Nonlinearity

This is the difference between the measured and the ideal 1 LSB change between any two adjacent codes in the ADC.

Offset Error

This is the deviation of the first code transition (0000. . .000) to (0000...001) from the ideal, i.e., AGND + 1 LSB.

Offset Error Match

This is the difference in offset error between any two channels.

Gain Error

This is the deviation of the last code transition (1111. . .110) to (1111. . .111) from the ideal, i.e., VREF - 1 LSB, after the offset error has been adjusted out.

Gain Error Match

This is the difference in Gain Error between any two channels.

Track/Hold Acquisition Time

Track/hold acquisition time is the time required for the output of the track/hold amplifier to reach its final value, within $\pm 1/2$ LSB, after the end of conversion (the point at which the track/hold returns to track mode). It also applies to situations where a change in the selected input channel takes place or where there is a step input change on the input voltage applied to the selected V_{IN} input of the AD7817. It means that the user must wait for the duration of the track/hold acquisition time after the end of conversion or after a channel change/step input change to V_{IN} before starting another conversion, to ensure that the part operates to specification.

CONTROL BYTE

The AD7817 contains two on-chip registers, The Address Register and the Over-Temperature Register. These registers can be accessed by carrying out an 8-bit serial write operation to the devices. The 8-bit word or Control Byte written to the AD7817 is transferred to one of the two on-chip registers as follows.

Address Register

If the 5 MSBs of the Control Byte are logic zero then the 3 LSBs of the Control Byte are transferred to the Address Register—see Figure 2. The Address Register is a 3-bit wide register which is used to select the analog input channel on which to carry out a conversion. It is also used to select the temperature sensor, which has the address 0 0 0. Table I below shows the selection. The Internal Ref Selection connects the input of the ADC to a band-gap reference. When this selection is made and a conversion is initiated, the ADC output should be approximately midscale. After power-up the default channel selection is DB2 = DB1 = DB0 = 0 (Temperature Sensor).

Table I. Channel Selection

DB2	DB1	DB0	Channel Selection
0	0	0	Temperature Sensor
0	0	1	Channel 1
0	1	0	Channel 2
0	1	1	Channel 3
1	0	0	Channel 4
1	1	1	Internal Ref (1.23 V)

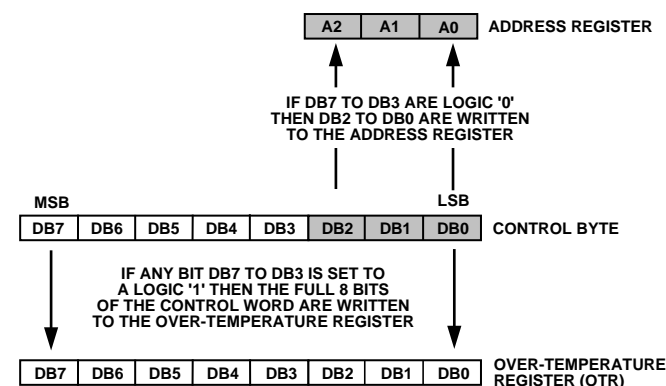

Figure 2. Address and Over-Temperature Register Selection

Over-Temperature Register

If any of the 5 MSBs of the control byte are logic one, the entire eight bits of the control byte are transferred to the over-temperature Register—see Figure 2. At the end of a temperature conversion, a digital comparison is carried out between the 8 MSBs of the temperature conversion result (10 bits) and the contents of the over-temperature register (8 bits). If the result of the temperature conversion is greater than the contents of the Over-Temperature Register (OTR), the Over-Temperature Indicator (\overline{OTI}) goes logic low. The resolution of the OTR is 1°C.

OVER-TEMPERATURE REGISTER									
MSB	DB7	DB6	DB5	DB4	DB3	DB2	DB1	LSB	DB0
	0	0	0	0	1	0	0		0
	1	1	1	1	1	1	1		1

OVER-TEMPERATURE REGISTER (DEC) = $T_{ALARM} + 103^{\circ}C$
 T_{ALARM} RESOLUTION = 1°/LSB

MINIMUM TEMPERATURE = -95°C
 MAXIMUM TEMPERATURE = +152°C

Figure 3. The Over-Temperature Register (OTR)

The lowest temperature that can be written to the OTR is -95°C and the highest is +152°C—see Figure 3. However the usable temperature range of the temperature sensor is -55°C to +125°C. Figure 2 shows the OTR and how to set T_{ALARM} (the temperature at which the \overline{OTI} goes low).

$$OTR (Dec) = T_{ALARM} (^{\circ}C) + 103^{\circ}C$$

For example to set T_{ALARM} to 50°C, $OTR = 50 + 103 = 153Dec$ or 10011001Bin. If the result of a temperature conversion exceeds 50°C, \overline{OTI} will go logic low. The \overline{OTI} logic output is reset high on the rising edge of the RD/\overline{WR} signal (see Figure 9) or if a new temperature measurement is lower than T_{ALARM} . The default power on T_{ALARM} is 50°C.

CIRCUIT INFORMATION

The AD7817 is a four-channel, 9 μs conversion time, 10-bit A/D converter with on-chip temperature sensor, reference and serial interface logic functions on a single chip. The A/D converter section consists of a conventional successive-approximation converter based around a capacitor DAC. The AD7817 is capable of running from a 2.7 V to 5.5 V power supply and accepting an analog input range of 0 V to + V_{REF} . The on-chip temperature sensor allows an accurate measurement of the ambient device temperature to be made. The working measurement range of the temperature sensor is -55°C to 125°C. The part requires a +2.5 V reference that can be provided from the part's own internal reference or from an external reference source.

CONVERTER DETAILS

Conversion is initiated by pulsing the \overline{CONVST} input. The conversion clock for the part is internally generated so no external clock is required except when reading from and writing to the serial port. The on-chip track/hold goes from track to hold mode and the conversion sequence is started on the falling edge of the \overline{CONVST} signal. At this point, the \overline{BUSY} signal goes high and low again (9 μs or 27 μs later, depending on whether an analog input or the temperature sensor is selected) to indicate the end of the conversion process. This signal can be used by a microcontroller to determine when the result of the conversion should be read. The track/hold acquisition time of the AD7817 is 400 ns.

A temperature measurement is made by selecting the Channel 0 of the on-chip MUX and carrying out a conversion on this channel. A conversion on Channel 0 takes 27 μs to complete. Temperature measurement is explained in the Temperature Measurement section.

The on-chip reference is not available to the user, but REF_{IN} can be overdriven by an external reference source (+2.5 V only). The effect of reference tolerances on temperature measurements is discussed in the Reference section.

All unused analog inputs should be tied to a voltage within the nominal analog input range to avoid noise pickup. For minimum power consumption, the unused analog inputs should be tied to AGND.

AD7817

TYPICAL CONNECTION DIAGRAM

Figure 4 shows a typical connection diagram for the AD7817. The AGND and DGND are connected together at the device for good noise suppression. The BUSY line is used to interrupt the microcontroller at the end of the conversion process and the serial interface is implemented using three wires—see Serial Interface section for more details. An external 2.5 V reference can be connected at the V_{REF} pin. If an external reference is used, a 10 nF capacitor should be connected between REF_{IN} and AGND. For applications where power consumption is of concern, the automatic power-down at the end of a conversion should be used to improve power performance. See Power-Down section.

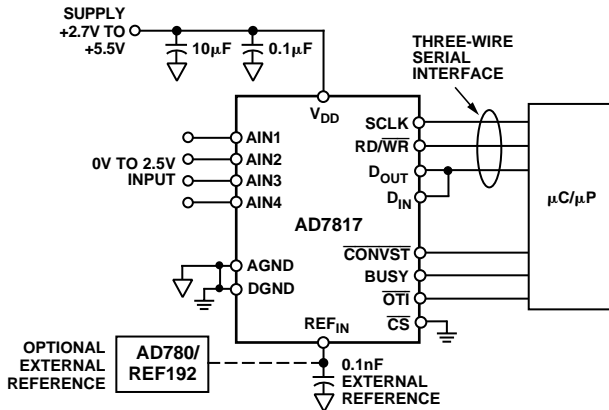

Figure 4. Typical Connection Diagram

ANALOG INPUTS

Analog Input

Figure 5 shows an equivalent circuit of the analog input structure of the AD7810. The two diodes D1 and D2 provide ESD protection for the analog inputs. Care must be taken to ensure that the analog input signal never exceeds the supply rails by more than 200 mV. This will cause these diodes to become forward biased and start conducting current into the substrate. The maximum current these diodes can conduct without causing irreversible damage to the part is 20 mA. The capacitor C2 in Figure 5 is typically about 4 pF and can mostly be attributed to pin capacitance. The resistor R1 is a lumped component made up of the on resistance of a multiplexer and a switch. This resistor is typically about 1 kΩ. The capacitor C1 is the ADC sampling capacitor and has a capacitance of 3 pF.

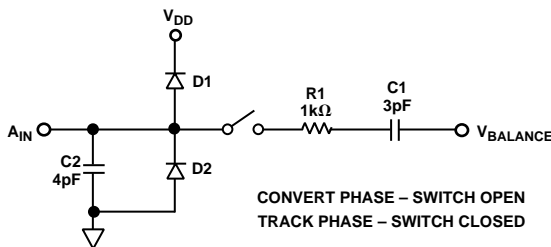

Figure 5. Equivalent Analog Input Circuit

DC Acquisition Time

The ADC starts a new acquisition phase at the end of a conversion and ends on the falling edge of the CONVST signal. At the end of a conversion there is a settling time associated with the

sampling circuit. This settling time lasts approximately 100 ns. The analog signal on V_{IN+} is also being acquired during this settling time. Therefore the minimum acquisition time needed is approximately 100 ns.

Figure 6 shows the equivalent charging circuit for the sampling capacitor when the ADC is in its acquisition phase. R2 represents the source impedance of a buffer amplifier or resistive network, R1 is an internal multiplexer resistance and C1 is the sampling capacitor.

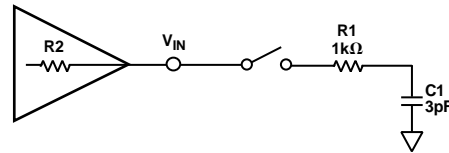

Figure 6. Equivalent Sampling Circuit

During the acquisition phase the sampling capacitor must be charged to within a 1/2 LSB of its final value. The time it takes to charge the sampling capacitor (T_{CHARGE}) is given by the following formula:

$$T_{CHARGE} = 7.6 \times (R2 + 1 \text{ k}\Omega) \times 3 \text{ pF}$$

For small values of source impedance, the settling time associated with the sampling circuit (100 ns) is, in effect, the acquisition time of the ADC. For example, with a source impedance (R2) of 10 Ω, the charge time for the sampling capacitor is approximately 23 ns. The charge time becomes significant for source impedances of 1 kΩ and greater.

AC Acquisition Time

In ac applications, it is recommended to always buffer analog input signals. The source impedance of the drive circuitry must be kept as low as possible to minimize the acquisition time of the ADC. Large values of source impedance will cause the THD to degrade at high throughput rates.

ON-CHIP REFERENCE

The AD7817 has an on-chip 1.2 V bandgap reference that is gained up to give an output of 2.5 V. The on-chip reference is selected by connecting the REF_{IN} pin to analog ground. This causes SW1—see Figure 7—to open and the reference amplifier to power-up during a conversion. Therefore the on-chip reference is not available externally. An external 2.5 V reference can be connected to the REF_{IN} pin. This has the effect of shutting down the on-chip reference circuitry and reducing I_{DD} to about 0.25 mA.

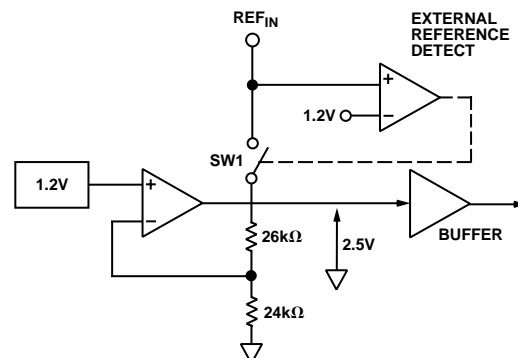

Figure 7. On-Chip Reference

ADC TRANSFER FUNCTION

The output coding of the AD7817 is straight binary. The designed code transitions occur at successive integer LSB values (i.e., 1 LSB, 2 LSBs, etc.). The LSB size is $= 2.5 \text{ V}/1024 = 2.44 \text{ mV}$. The ideal transfer characteristic is shown in Figure 8.

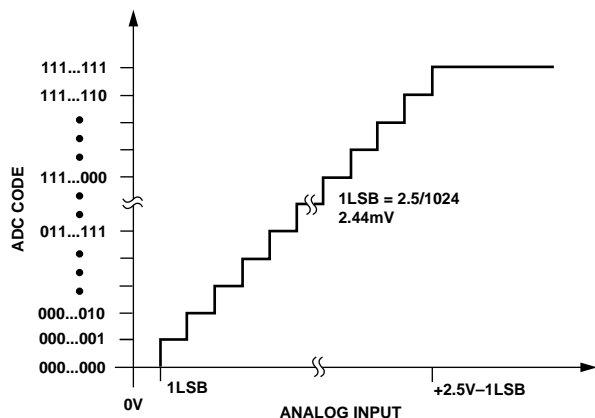

Figure 8. ADC Transfer Function

TEMPERATURE MEASUREMENT

The on-chip temperature sensor can be accessed via multiplexer Channel 0, i.e., by writing 0 0 0 to the Channel Address Register. The temperature is also the power-on default selection. The transfer characteristic of the temperature sensor is shown in Figure 9. The result of the 10-bit conversion on Channel 0 can be converted to a temperature by using the following equation:

$$T_{AMB} = -103^{\circ}\text{C} + (\text{ADC Code}/4)$$

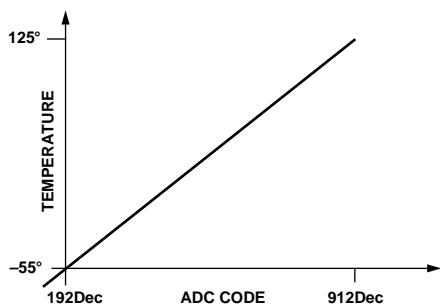

Figure 9. Temperature Sensor Transfer Characteristic

For example, if the result of a conversion on Channel 0 was 1000000000 (512 Dec), the ambient temperature is equal to $-103^{\circ}\text{C} + (512/4) = 25^{\circ}\text{C}$.

Table II below shows some ADC codes for various temperatures.

Table II. Temperature Sensor Output

ADC Code	Temperature
00 1100 0000	-55°C
01 0011 1000	-25°C
01 1001 1100	0°C
10 0000 0000	+25°C
10 0111 1000	+55°C
11 1001 0000	+125°C

TEMPERATURE MEASUREMENT ERROR DUE TO REFERENCE ERROR

The AD7817 is trimmed using a precision 2.5 V reference to give the transfer function described above. To show the effect of the reference tolerance on a temperature reading, the temperature sensor transfer function can be rewritten as a function of the reference voltage and the temperature.

$$\text{CODE (Dec)} = \left(\frac{113.3285 \times K \times T}{q \times V_{REF}} - 0.6646 \right) \times 1024$$

where K = Boltzmann's Constant, 1.38×10^{-23}
 q = charge on an electron, 1.6×10^{-19}
 T = Temperature ($^{\circ}\text{K}$)

For example, to calculate the ADC code at 25°C

$$\begin{aligned} \text{CODE} &= \left(\frac{113.3285 \times 298 \times 1.38 \times 10^{-23}}{1.6 \times 10^{-19} \times 2.5} - 0.6646 \right) \times 1024 \\ &= 511.5 \text{ (200 Hex)} \end{aligned}$$

As can be seen from the expression a reference error will produce a gain error. This means the temperature measurement error due to reference error will be greater at higher temperatures. For example, with a reference error of -1% the measurement error at -55°C would be +2.2 LSBs (0.5°C) and +16 LSBs (4°C) at $+125^{\circ}\text{C}$.

SELF-HEATING CONSIDERATIONS

The AD7817 has an analog-to-digital conversion function capable of a throughput rate of 100 kSPS. At this throughput rate the AD7817 consumes 6 mW of power. Because of this the temperature of the die will rise as a result of this power dissipation. The graphs below show the self-heating effect in free air and on a four-layer PCB for a 16-lead SOIC package. Placing the package on a four-layer PCB reduces the thermal impedance associated with the package and thus reduces the self-heating of the die.

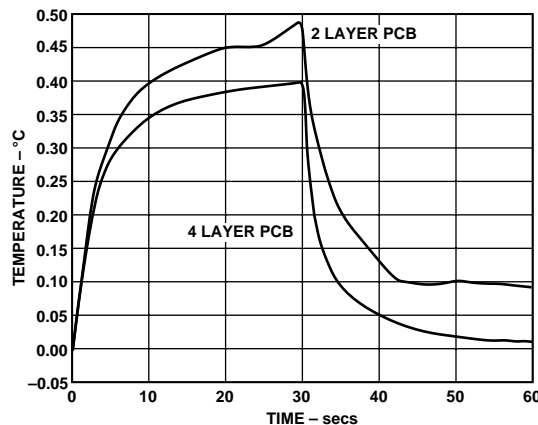

Figure 10. Self-Heating Effect Two-Layer and Four-Layer PCB

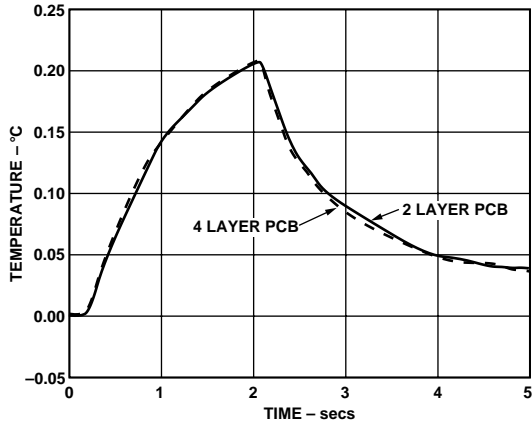

Figure 11. Self-Heating Effect Two-Layer and Four-Layer PCB

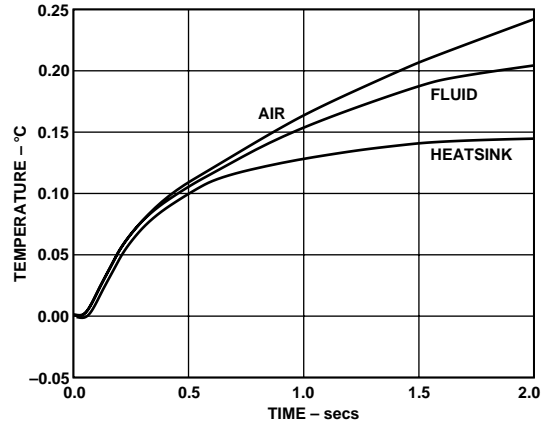

Figure 13. Self-Heating Effect in Air, Fluid and in Thermal Contact with a Heatsink

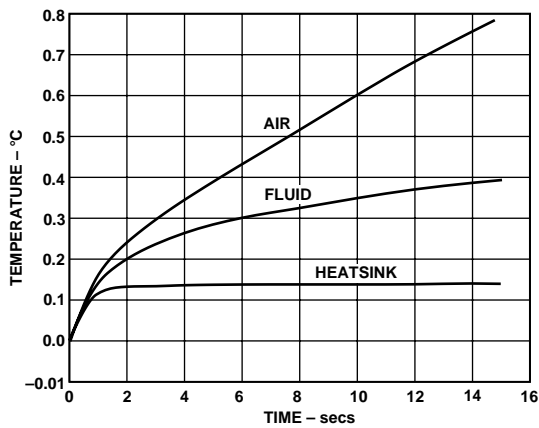

Figure 12. Self-Heating Effect in Air, Fluid and in Thermal Contact with a Heatsink

OPERATING MODES

The AD7817 has two possible modes of operation, depending on the state of the $\overline{\text{CONVST}}$ pulse at the end of a conversion.

Mode 1

In this mode the $\overline{\text{CONVST}}$ pulse is brought high before the end of a conversion, i.e., before the BUSY goes low (see Figure 14). When operating in this mode a new conversion should not be initiated until 100 ns after the end of a serial read or write operation. This quiet time is to allow the Track/Hold to accurately acquire the input signal after a serial read.

Mode 2

When the AD7817 is operated in mode 2 (see Figure 15), it automatically powers down at the end of a conversion. The $\overline{\text{CONVST}}$ is brought low to initiate a conversion and is left logic low until after the end of the conversion. At this point, i.e., when BUSY goes low, the device will power down. The device is powered up again on the rising edge of the $\overline{\text{CONVST}}$ signal. Superior power performance can be achieved in this mode of operation by only powering up the AD7817 to carry out a conversion. See Power vs. Throughput section.

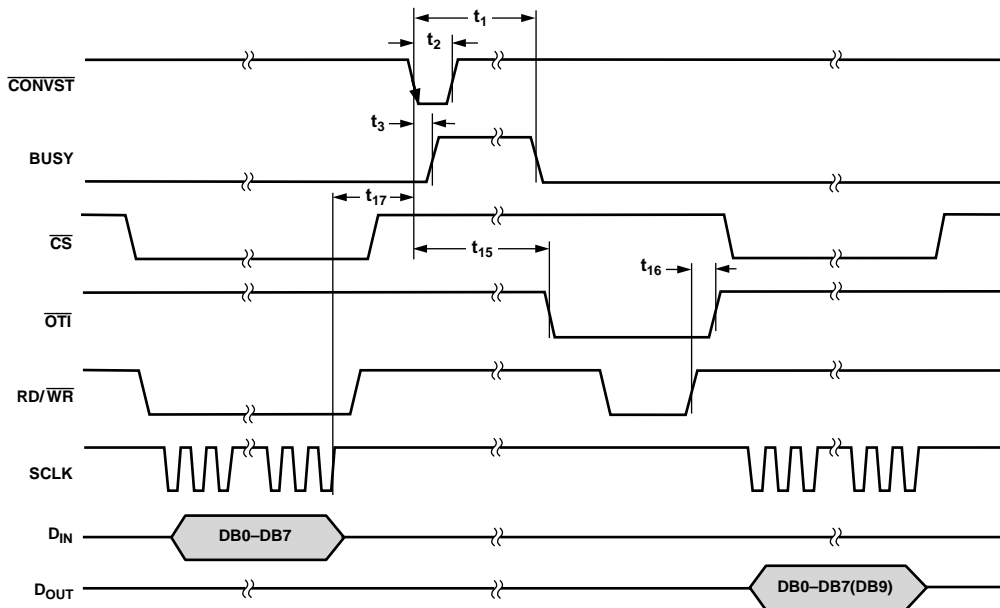

Figure 14. Mode 1 Operation

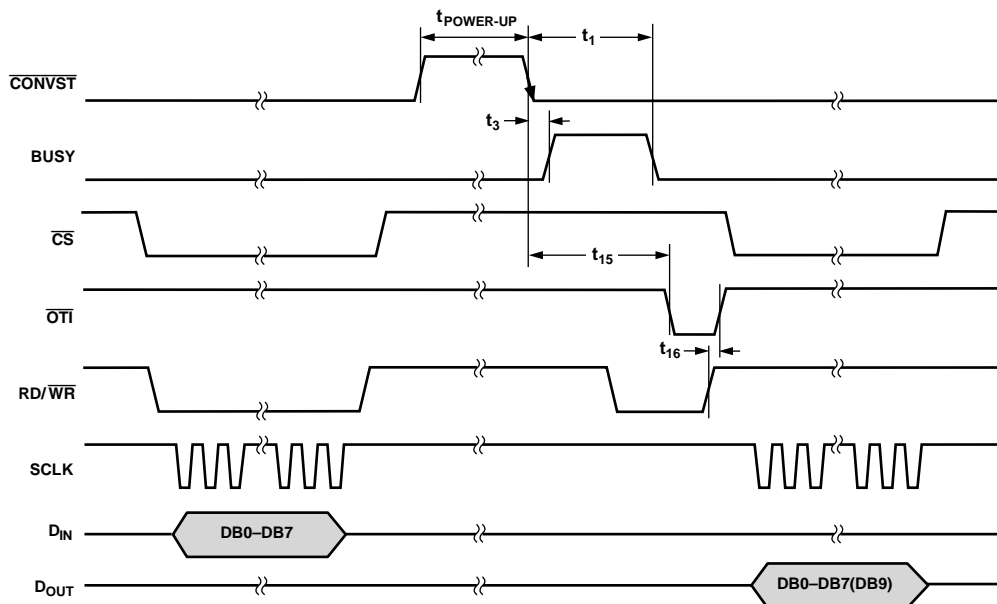

Figure 15. Mode 2 Operation

POWER VS. THROUGHPUT

By using the Automatic Power-Down (Mode 2) at the end of a conversion—see Operating Modes section of the data sheet—superior power performance can be achieved.

Figure 16 shows how the Automatic Power-Down is implemented to achieve the optimum power performance from the AD7817. The devices are operated in Mode 2 and the duration of CONVST pulse is set to be equal to the power-up time ($2\ \mu\text{s}$). As the throughput rate of the device is reduced, the device remains longer in its power-down state and the average power consumption over time drops accordingly.

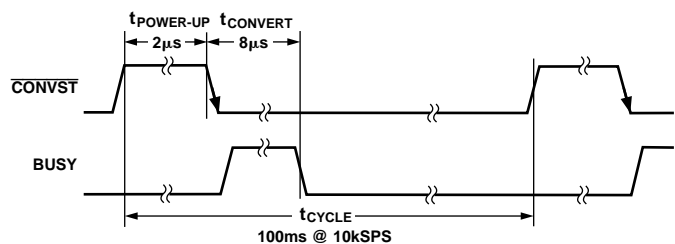

Figure 16. Automatic Power-Down

For example, if the AD7817 is operated in a continuous sampling mode with a throughput rate of 10 kSPS, the power consumption is calculated as follows. The power dissipation during normal operation is 6 mW, $V_{DD} = 3\ \text{V}$. If the power-up time is $2\ \mu\text{s}$ and the conversion time is $9\ \mu\text{s}$, the AD7817 can be said to dissipate 6 mW typically for $11\ \mu\text{s}$ (worst case) during each conversion cycle. If the throughput rate is 10 kSPS, the cycle time is $100\ \mu\text{s}$ and the power dissipated during each cycle is $(11/100) \times (6\ \text{mW}) = 600\ \mu\text{W}$ typ.

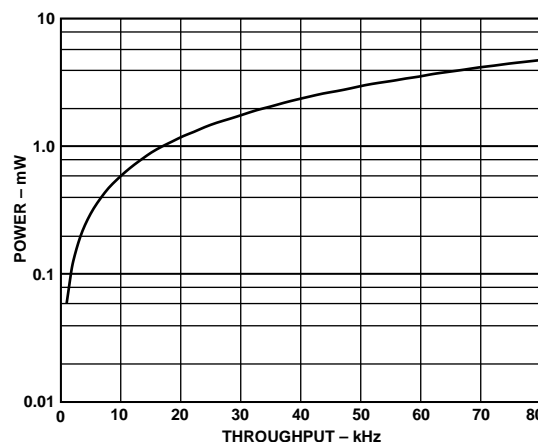

Figure 17. Power vs. Throughput Rate

SERIAL INTERFACE

The serial interface on the AD7817 is a five-wire interface with read and write capabilities, with data being read from the output register via the D_{OUT} line and data being written to the control register via the D_{IN} line. The part operates in a slave mode and requires an externally applied serial clock to the SCLK input to access data from the data register or write the control byte. The RD/\overline{WR} line is used to determine whether data is being written to or read from the AD7817. When data is being written to the AD7817, the RD/\overline{WR} line is set logic low; when data is being read from the part, the line is set logic high—see Figure 18. The serial interface on the AD7817 is designed to allow the part to be interfaced to systems that provide a serial clock that is synchronized to the serial data, such as the 80C51, 87C51, 68HC11, 68HC05 and PIC16Cxx microcontrollers.

AD7817

Read Operation

Figure 18 shows the timing diagram for a serial read from the AD7817. \overline{CS} is brought low to enable the serial interface and RD/\overline{WR} is set logic high to indicate that the data transfer is a serial read from the AD7817. The rising edge of RD/\overline{WR} clocks out the first data bit (DB9), subsequent bits are clocked out the falling edge of SCLK and are valid on the rising edge. Ten bits of data are transferred during a read operation. However, the user has the choice of clocking only eight bits if the full ten bits of the conversion result are not required. The serial data can be accessed in a number of bytes if ten bits of data are being read. However, RD/\overline{WR} must remain high for the duration of the data transfer operation. Before starting a new data read operation the RD/\overline{WR} signal must be brought low and high again. At the end of the read operation, the D_{OUT} line enters a high impedance state on the rising edge of the \overline{CS} or the falling edge of RD/\overline{WR} , whichever occurs first.

Write Operation

Figure 18 shows a control byte write operation to the AD7817. The RD/\overline{WR} input goes low to indicate to the part that a serial write is about to occur. The AD7817 control byte is loaded on the rising edge of the first eight clock cycles of the serial clock with data on all subsequent clock cycles being ignored. To carry out a second successive write operation the RD/\overline{WR} signal must be brought high and low again.

Simplifying the Serial Interface

To minimize the number of interconnect lines to the AD7817, the user can connect the \overline{CS} line to DGND. This is possible if the AD7817 is not sharing the serial bus with another device. It is also possible to tie the D_{IN} and D_{OUT} lines together. This arrangement is compatible with the 8051 microcontroller. The 68HC11, 68HC05 and PIC16Cxx can be configured to operate with a single serial data line. In this way the number of lines required to operate the serial interface can be reduced to three, i.e., RD/\overline{WR} , SCLK and $D_{IN/OUT}$ —See Figure 4.

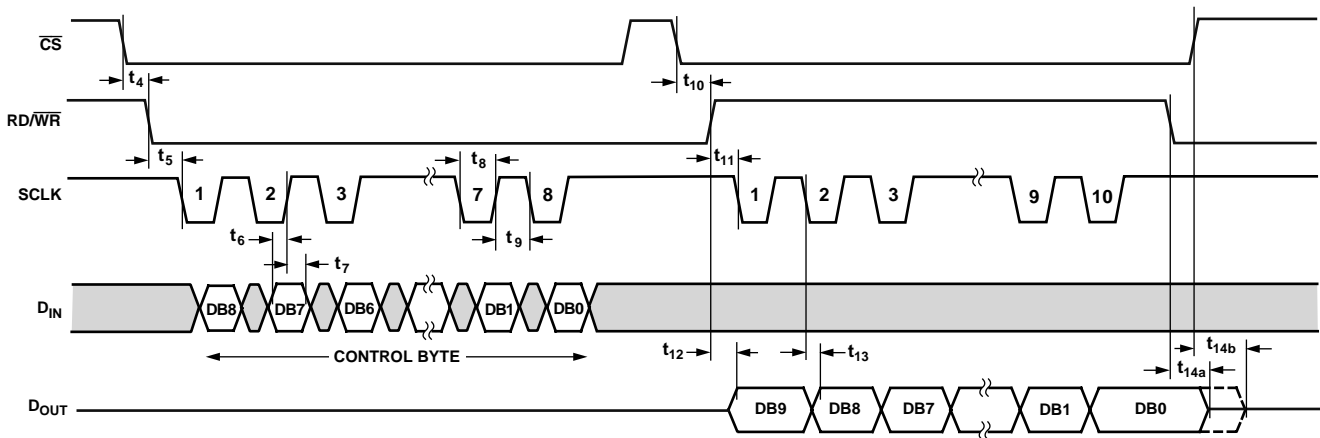
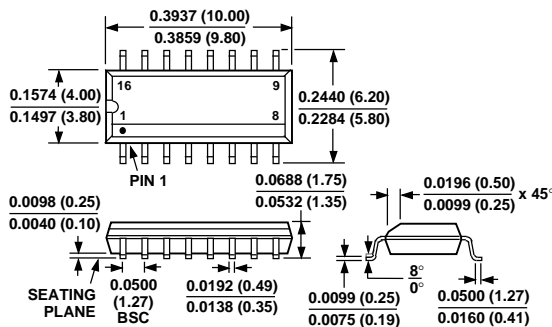

Figure 18. AD7817 Serial Interface Timing Diagram

OUTLINE DIMENSIONS

Dimensions shown in inches and (mm).

16-Lead Narrow Body SOIC (R-16A)



16-Lead Thin Shrink Small Outline Package (TSSOP) (RU-16)

