

GENERAL DESCRIPTION

The ADXL202EB is a simple evaluation board that allows you to quickly evaluate the performance of the ADXL202 dual axis ± 2 g accelerometer. You must add only three additional through-hole passive components depending on the bandwidth required in your application. The ADXL202EB has a 5 pin 0.1 inch spaced header for access to all power and signal lines that you may attach to a prototyping board (breadboard) or wire via a standard plug. Two holes are provided for mechanical attachment of the ADXL202EB to your application.

CIRCUIT DESCRIPTION

The schematic and parts list of the ADXL202EB is shown in figure 1 and table 1 respectively. The minimal application will require at least resistor (Rset) added to the board to set the PWM period (T2). Analog bandwidth may be set by adding capacitors C2 and C3. Refer to the ADXL202 data sheet for a complete description of the operation of the accelerometer.

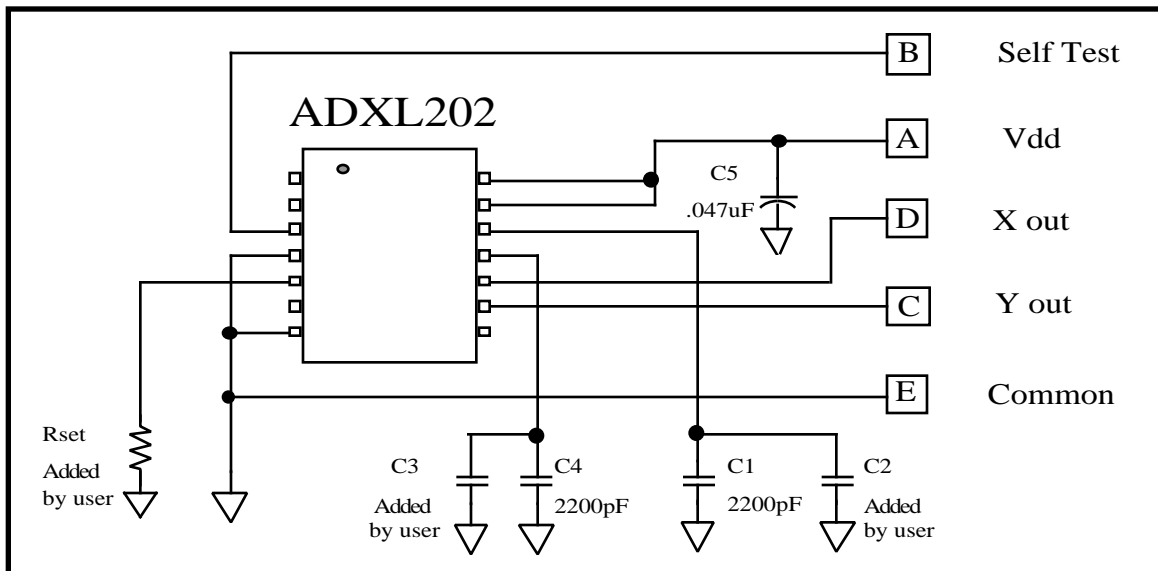

Figure 1. ADXL202EB Schematic

The part layout of the ADXL202EB is shown in figure 2. The ADXL202EB has two factory installed 2200 pF capacitors (C1 and C4) at Xfilt and Yfilt to satisfy the minimum filter capacitor specification of the ADXL202. Your application will likely require narrower bandwidth (and lower noise), in which case you may add a through-hole capacitor in parallel in the space provided at C2 and C3 respectively. When calculating the capacitance required to achieve your desired analog bandwidth do not forget to subtract the 2200 pF already on the PCB.

The pin out description of the ADXL202EB is shown below in table 2.

SETTING THE PERIOD OF THE DUTY CYCLE MODULATOR

The DCM period is set by Rset. Choose a value between 100 k Ω and 2 M Ω . See table 3 for some typical Rset values.

Table 1. ADXL202EB Parts List

REFERENCE	VALUE	FUNCTION
C1	2200 pF / 25V	Xfilt. Sets X axis analog bandwidth along with C2
C2	Added by user	Xfilt. Sets X axis analog bandwidth along with C1
C3	Added by user	Yfilt. Sets Y axis analog bandwidth along with C4
C4	2200 pF / 25V	Yfilt. Sets Y axis analog bandwidth along with C3
J1	Connector	All power and signal connection through J1
R1	Added by user	Rset. Sets the PWM period (T2)
U1	ADXL202	Dual axis 0.2g accelerometer

Table 2. ADXL202EB Pin-Out Description

PIN REFERENCE	FUNCTION
E	GROUND
B	SELF TEST INPUT
D	X AXIS DUTY CYCLE OUT
C	Y AXIS DUTY CYCLE OUT
A	+V SUPPLY (3 to 5.25 VDC)

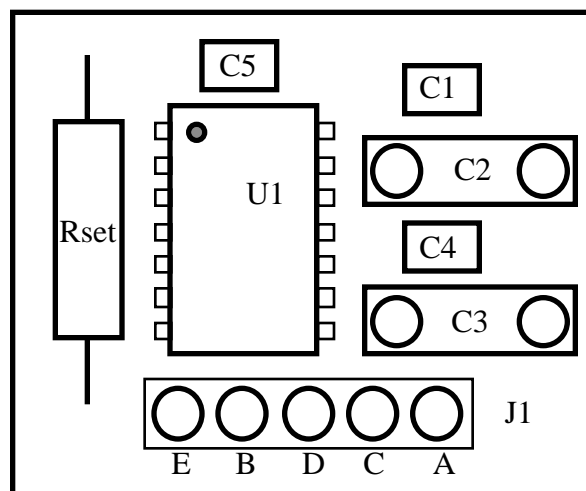

Table 3. DCM Period vs Rset Value

T2 PERIOD	Rset
1 mS	124 k
2 mS	248 k
5 mS	620 k
10 mS	1.24 M

Figure 2. ADXL202EB Part Layout (Top View)

SETTING THE BANDWIDTH OF THE ADXL202

The ADXL202EB is supplied with the minimum specified Xfilt and Yfilt values installed. Your application will likely require a narrower bandwidth to improve noise performance. See table 4 for some typical capacitor values.

Table 4. Typical Xfilt and Yfilt Values vs Bandwidth and Noise Performance

Xfilt, Yfilt	BANDWIDTH	RMS NOISE
0.01 μ F	500 Hz	12.7 mg
0.047 μ F	100 Hz	7 mg
0.1 μ F	50 Hz	4.2 mg
0.47 μ F	10 Hz	2.3 mg

SPECIAL NOTES ON HANDLING

Note that the ADXL202EB is not reverse polarity protected. Reversing the +Vsupply and Ground pins will damage the ADXL202.

Dropping the ADXL202EB on a hard surface may generate several thousand g of acceleration. Enough to damage the accelerometer. Please refer to the ADXL202 data sheet for information on shock survivability.