

## SSM-2402/SSM-2412

### FEATURES

- "Clickless" Bilateral Audio Switching
- Guaranteed "Break-Before-Make" Switching
- Low Distortion ..... 0.003% Typ
- Low Noise ..... 1nV/ $\sqrt{\text{Hz}}$
- Superb OFF-Isolation ..... 120dB Typ
- Low ON-Resistance ..... 60 $\Omega$  Typ
- Wide Signal Range:  
 $V_s = \pm 18V$  ..... 10V RMS
- Wide Power Supply Range .....  $\pm 20V$  Max
- Available in Dice Form

### ORDERING INFORMATION

PACKAGE		OPERATING TEMPERATURE RANGE
PLASTIC 14-PIN	SOL 16-PIN	
SSM2402P	SSM2402S	XIND*
SSM2412P	SSM2412S	XIND*

\*XIND = -40°C to +85°C

### GENERAL DESCRIPTION

The SSM-2402/2412 are dual analog switches designed specifically for high-performance audio applications. Distortion and noise are negligible over the full audio operating range of 20Hz to 20kHz at signal levels of up to 10V<sub>RMS</sub>. The SSM-2402/2412 offer a monolithic integrated alternative to expensive and noisy relays or complex discrete JFET circuits. Unlike conventional general-purpose CMOS switches, the SSM-2402/2412 provide superb fidelity without audio "clicks" during switching.

Conventional TTL or CMOS logic can be used to control the switch state. No external pull-up resistors are needed. A "T" configuration provides superb OFF-isolation and true bilateral operation. The analog inputs and outputs are protected against overload and overvoltage.

An important feature is the guaranteed "break-before-make" for all units, even IC-to-IC. In large systems with multiple switching channels, all separate switching units must open before any switch goes into the ON-state. With the SSM-2402/2412, you can be certain that multiple circuits will all break-before-make.

The SSM-2402/2412 represent a significant step forward in audio switching technology. Distortion and switching noise are significantly reduced in the new SSM-2402/2412 bipolar-JFET switches relative to CMOS switching technology. Based on a

new circuit topology that optimizes audio performance, the SSM-2402/2412 make use of a proprietary bipolar-JFET process with thin-film resistor network capability. Nitride capacitors, which are very area efficient, are used for the proprietary ramp generator that controls the switch resistance transition. Very wide bandwidth amplifiers control the gate-to-source voltage over the full audio operating range for each switch. The ON-resistance remains constant with changes in signal amplitude and frequency, thus distortion is very low, less than 0.01% Max.

The SSM-2402 is the first analog switch truly optimized for high-performance audio applications. For broadcasting and other switching applications which require a faster switching time, we recommend the SSM-2412 – a dual analog switch with one-third of the switching time of the SSM-2402.

### PIN CONNECTIONS

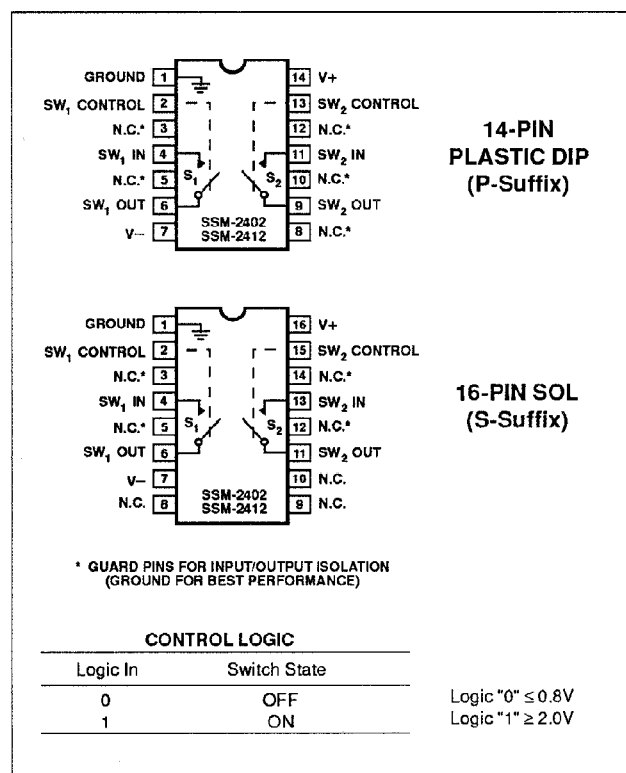

# SSM-2402/SSM-2412

## FUNCTIONAL DIAGRAM

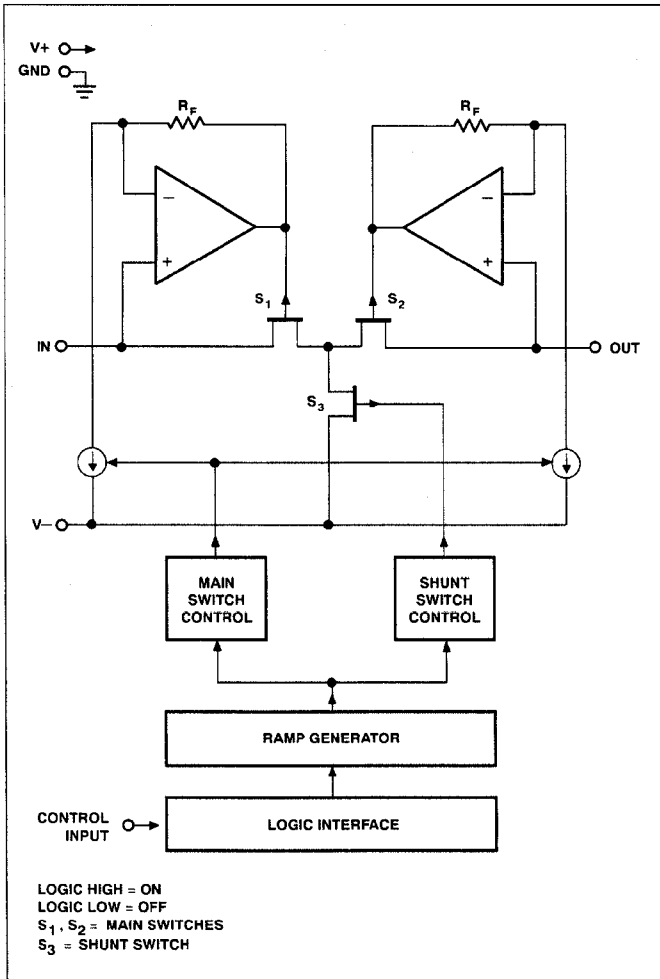

## TIMING DIAGRAM

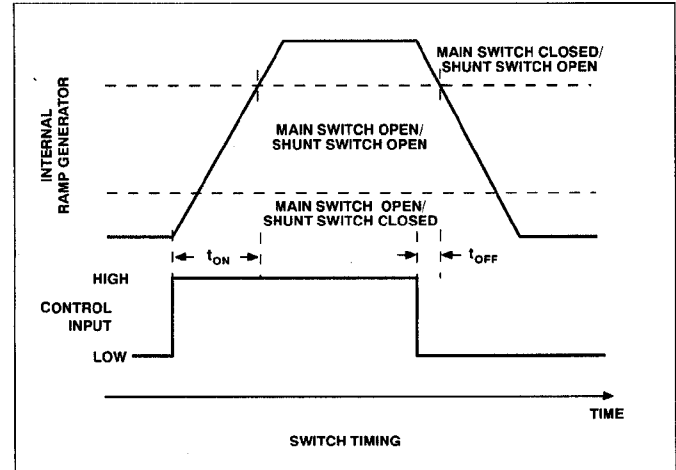

## ABSOLUTE MAXIMUM RATINGS

Operating Temperature Range	.....	-40°C to +85°C
Operating Supply Voltage Range	.....	±20V
Analog Input Voltage Range	.....	$V_- + 3.5V \leq V_A \leq V_+ - 3.5V$
Maximum Current Through Switch	.....	20mA
Logic Input Voltage Range	.....	$V_+$ Supply to -2V
$V_+$ Supply to Ground	.....	+36V
$V_-$ Supply to Ground	.....	-20V
$V_A$ to $V_-$ Supply	.....	+36V

PACKAGE TYPE	$\theta_{JA}$ (NOTE 1)	$\theta_{JC}$	UNITS
14-Pin Plastic DIP (P)	76	33	°C/W
16-Pin SOL (S)	92	27	°C/W

### NOTE:

- $\theta_{JA}$  is specified for worst case mounting conditions, i.e.,  $\theta_{JA}$  is specified for device in socket for P-DIP package;  $\theta_{JA}$  is specified for device soldered to printed circuit board for SOL package.

## ELECTRICAL CHARACTERISTICS at $V_S = \pm 18V$ , $R_L = OPEN$ , and $-40^\circ C \leq T_A \leq +85^\circ C$ , unless otherwise noted.

All specifications, tables, graphs, and application data apply to both the SSM-2402 and SSM-2412, unless otherwise noted.

PARAMETER	SYMBOL	CONDITIONS	SSM-2402/2412			UNITS
			MIN	TYP	MAX	
Positive Supply Current	$+I_{SY}$	$V_{IL} = 0.8V, 2.0V$ (Note 1)	-	6.0	7.5	mA
Negative Supply Current	$-I_{SY}$	$V_{IL} = 0.8V, 2.0V$ (Note 1)	-	4.8	6.0	mA
Ground Current	$I_{GND}$	$V_{IL} = 0.8V, 2.0V$ (Note 1)	-	0.6	1.5	mA
Digital Input High	$V_{INH}$	$T_A = \text{Full Temperature Range}$	2.0	-	-	V
Digital Input Low	$V_{INL}$	$T_A = \text{Full Temperature Range}$	-	-	0.8	V
Logic Input Current	$I_{LOGIC}$	$V_{IN} = 0 \text{ to } 15V$ (Note 2)	-	1.0	5.0	$\mu A$
Analog Voltage Range (Note 3)	$V_{ANALOG}$		-14.2	-	+14.2	V

# SSM-2402/SSM-2412

**ELECTRICAL CHARACTERISTICS** at  $V_S = \pm 18V$ ,  $R_L = OPEN$ , and  $-40^\circ C \leq T_A \leq +85^\circ C$ , unless otherwise noted. *Continued*

PARAMETER	SYMBOL	CONDITIONS	SSM-2402/2412			UNITS
			MIN	TYP	MAX	
Analog Current Range (Note 3)	$I_{ANALOG}$		-10	-	+10	mA
Overvoltage Input Current		$V_{IN} = \pm V_{SUPPLY}$	-	$\pm 40$	-	mA
Switch ON Resistance	$R_{ON}$	$-14.2 \leq V_A \leq +14.2V$	-	60	85	$\Omega$
		$I_A = \pm 10mA, V_{IL} = 2.0V$	-	-	115	$\Omega$
		$T_A = +25^\circ C$	-	-	-	$\Omega/^\circ C$
		$T_A = \text{Full Temperature Range}$ Tempco ( $\Delta R_{ON}/\Delta T$ )	-	0.2	-	
$R_{ON}$ Match	$R_{ONMATCH}$	$-14.2 \leq V_A \leq +14.2V$ $I_A = \pm 10mA, V_{IL} = 2.0V$	-	1	5	%
Switch ON Leakage Current (Notes 1, 2)	$I_{S(ON)}$	$V_{IL} = 2.0V$	-	0.05	1.0	$\mu A$
		$-14.2V \leq V_A \leq +14.2V$ $V_A = 0V$	-	0.05	10.0	nA
Switch OFF Leakage Current (Notes 1, 2)	$I_{S(OFF)}$	$V_{IL} = 0.8V$	-	0.05	1.0	$\mu A$
		$-14.2V \leq V_A \leq +14.2V$ $V_A = 0V$	-	0.05	10.0	nA
Turn-On Time (Note 4)	$t_{ON}$	$V_A = +10V, R_L = 2k\Omega$	-	10.0	-	ms
		$T_A = +25^\circ C$ , See Test Circuit	-	3.5	-	
Turn-Off Time (Note 5)	$t_{OFF}$	$V_A = +10V, R_L = 2k\Omega$	-	4.0	-	ms
		$T_A = +25^\circ C$ , See Test Circuit	-	1.5	-	
Break-Before-Make Time Delay (Note 6)	$t_{OFF} - t_{ON}$	$T_A = +25^\circ C$	-	6.0	-	ms
			-	2.0	-	
Charge Injection	Q	$T_A = +25^\circ C$	-	50	-	pC
			-	150	-	
ON-State Input Capacitance	$CS_{(ON)}$	$V_A = 1V_{RMS}$ $f = 5kHz, T_A = +25^\circ C$	-	12	-	pF
OFF-State Input Capacitance	$CS_{(OFF)}$	$V_A = 1V_{RMS}$ $f = 5kHz, T_A = +25^\circ C$	-	4	-	pF
OFF Isolation	$I_{SO(OFF)}$	$V_A = 10V_{RMS}, 20Hz$ to 20kHz $T_A = +25^\circ C$ , See Test Circuit	-	120	-	dB
Channel-to-Channel Crosstalk	$C_T$	$V_A = 10V_{RMS}, 20Hz$ to 20kHz $T_A = +25^\circ C$	-	96	-	dB
Total Harmonic Distortion (Note 7)	THD	0 to $10V_{RMS}, 20Hz$ to 20kHz $T_A = +25^\circ C, R_L = 5k\Omega$	-	0.003	0.01	%
Spectral Noise Density	$e_n$	20Hz to 20kHz $T_A = +25^\circ C$	-	1	-	$nV/\sqrt{Hz}$
Wideband Noise Density	$e_{n\text{ p-p}}$	20Hz to 20kHz $T_A = +25^\circ C$	-	0.2	-	$\mu V_{p-p}$

**NOTES:**

- " $V_{IL}$ " is the Logic Control Input.
- Current tested at  $V_{IN} = 0V$ . This is the worst case condition.
- Guaranteed by  $R_{ON}$  test condition.
- Turn-ON Time is measured from the time the logic input reaches the 50% point to the time the output reaches 50% of the final value.
- Turn-OFF time is measured from the time the logic input reaches the 50% point to the time the output reaches 50% of the initial value.
- Switch is guaranteed by design to provide break-before-make operation.
- THD guaranteed by design and dynamic  $R_{ON}$  testing.

# SSM-2402/SSM-2412

## DICE CHARACTERISTICS

**SSM-2402/SSM-2412**

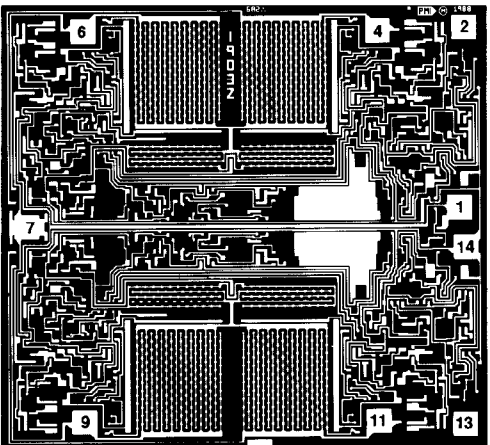

1. GROUND
2. SWITCH<sub>1</sub> CONTROL
4. SWITCH<sub>1</sub> IN
6. SWITCH<sub>1</sub> OUT
7. V- SUPPLY
9. SWITCH<sub>2</sub> IN
11. SWITCH<sub>2</sub> OUT
13. SWITCH<sub>2</sub> CONTROL
14. V+ SUPPLY

**DIE SIZE 0.105 x 0.097 inch, 10,185 sq. mils  
(2.667 x 2.464 mm, 6.57 sq. mm)**

For additional DICE information, refer to PMI's Data Book, Section 2.

### WAFER TEST LIMITS at $V_S = \pm 18V$ , $R_L = OPEN$ , and $T_A = +25^\circ C$ .

PARAMETER	SYMBOL	CONDITIONS (Note 1)	SSM-2402/2412NBC LIMIT	UNITS
Positive Supply Current	$+I_{SY}$	$V_{IL} = 0.8V$	7.5	mA MAX
Negative Supply Current	$-I_{SY}$	$V_{IL} = 0.8V$	6.0	mA MAX
Ground Current	$I_{GND}$	$V_{IL} = 0.8V$	1.5	mA MAX
Logic Input Current	$I_{LOGIC}$	$V_{IN} = 0V$ (Note 2)	5.0	$\mu A$ MAX
Switch ON Resistance	$R_{ON}$	$-14.2 \leq V_A \leq +14.2V$ $I_A = \pm 10mA, V_{IL} = 2.0V$	85	$\Omega$ MAX
$R_{ON}$ Match Between Switches	$R_{ONMATCH}$	$-14.2V \leq V_A \leq +14.2V$ $I_A = \pm 10mA, V_{IL} = 2.0V$	5	% MAX
Switch ON Leakage Current	$I_{S(ON)}$	$-14.2V \leq V_A \leq +14.2V$ $V_{IL} = 2.0V$	1.0	$\mu A$ MAX
Switch OFF Leakage Current	$I_{S(OFF)}$	$-14.2V \leq V_A \leq +14.2V$ $V_{IL} = 0.8V$	1.0	$\mu A$ MAX

#### NOTES:

1.  $V_{IL}$  = Logic Control Input  
 $V_A$  = Applied Analog Input Voltage  
 $I_A$  = Applied Analog Input Current
2. Worst Case Condition

Electrical tests are performed at wafer probe to the limits shown. Due to variations in assembly methods and normal yield loss, yield after packaging is not guaranteed for standard product dice. Consult factory to negotiate specifications based on dice lot qualifications through sample lot assembly and testing.

TYPICAL PERFORMANCE CHARACTERISTICS

TOTAL HARMONIC DISTORTION vs FREQUENCY

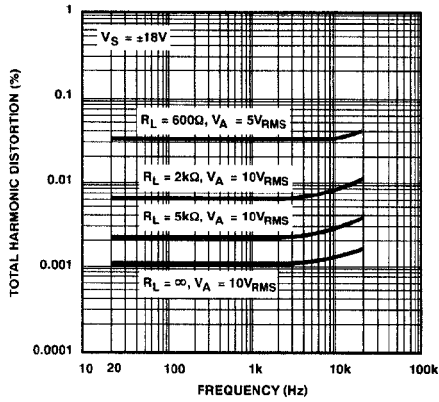

"OFF" ISOLATION vs FREQUENCY

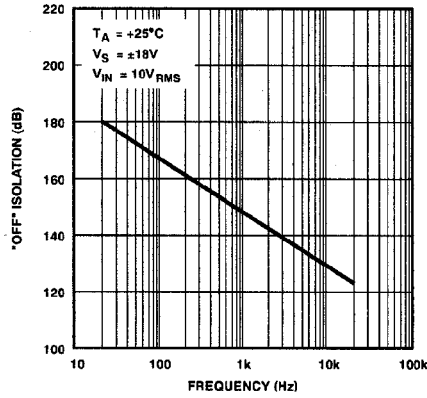

"ON" RESISTANCE vs ANALOG VOLTAGE

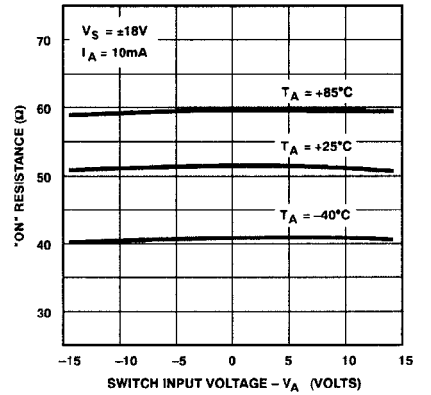

SSM-2402 SWITCHING TIME vs TEMPERATURE

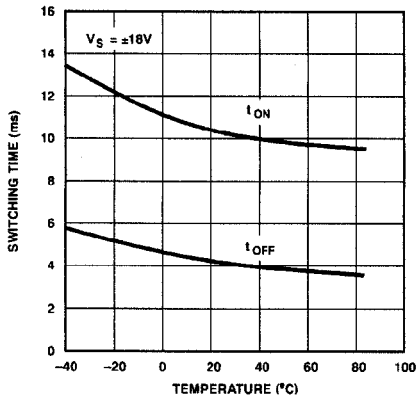

SSM-2412 SWITCHING TIME vs TEMPERATURE

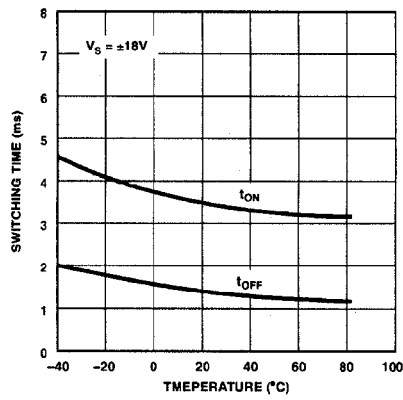

CHANNEL SEPARATION vs FREQUENCY

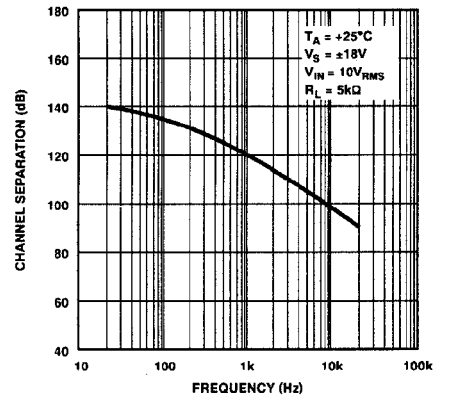

SUPPLY CURRENT vs TEMPERATURE

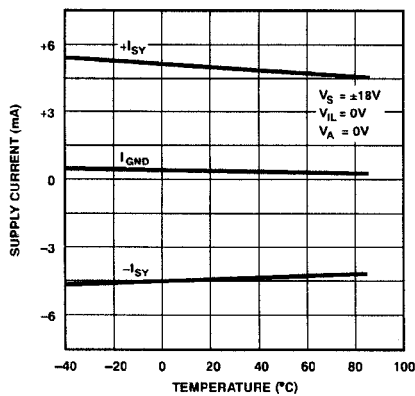

OVERVOLTAGE CHARACTERISTICS

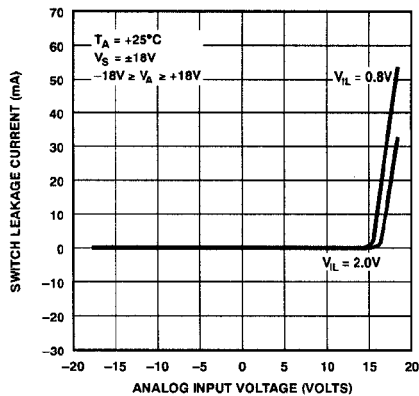

LEAKAGE CURRENT vs ANALOG VOLTAGE

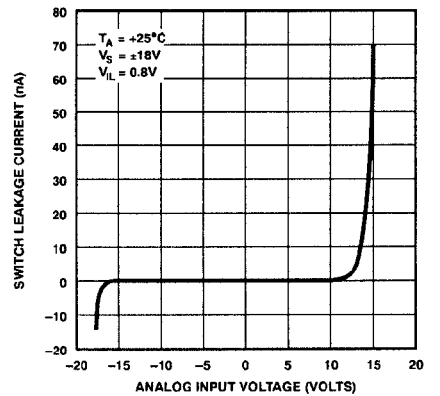

# SSM-2402/SSM-2412

## TYPICAL PERFORMANCE CHARACTERISTICS *Continued*

### SSM-2402 $T_{ON}/T_{OFF}$ SWITCHING RESPONSE

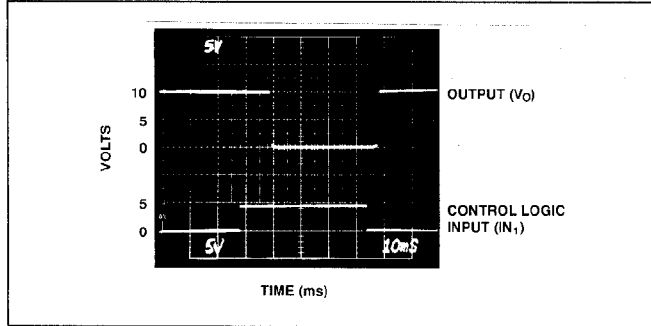

### SSM-2412 $T_{ON}/T_{OFF}$ SWITCHING RESPONSE

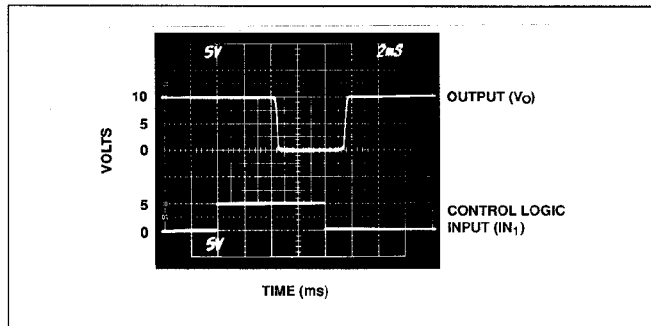

### SWITCHING ON/OFF TRANSITION

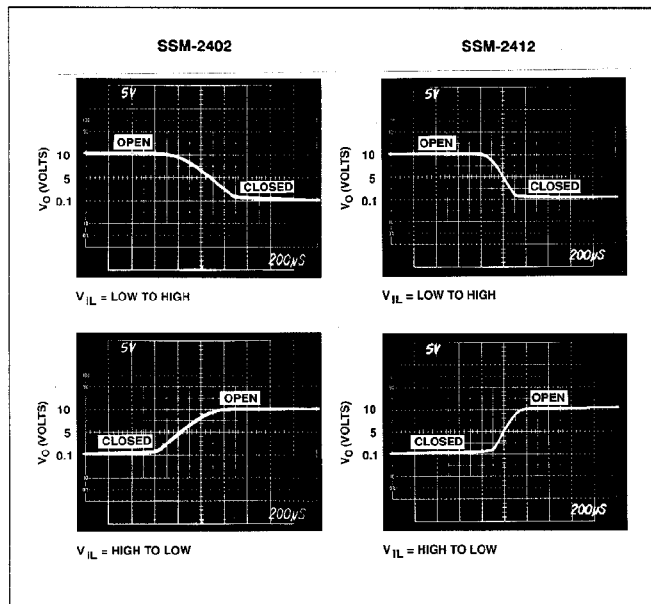

### $T_{ON}/T_{OFF}$ SWITCHING RESPONSE TEST CIRCUIT

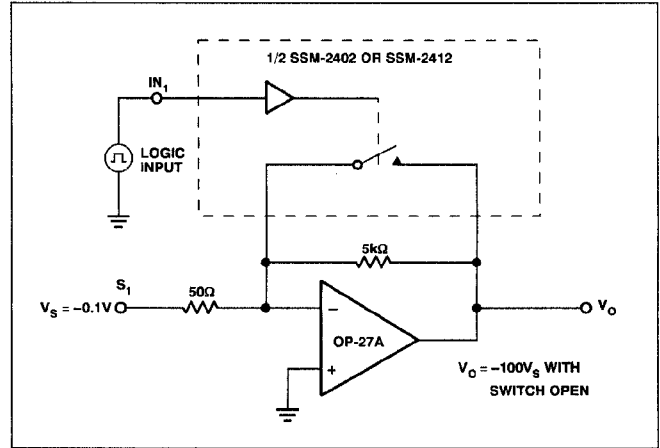

### SWITCH ON/OFF TRANSITION TEST CIRCUIT

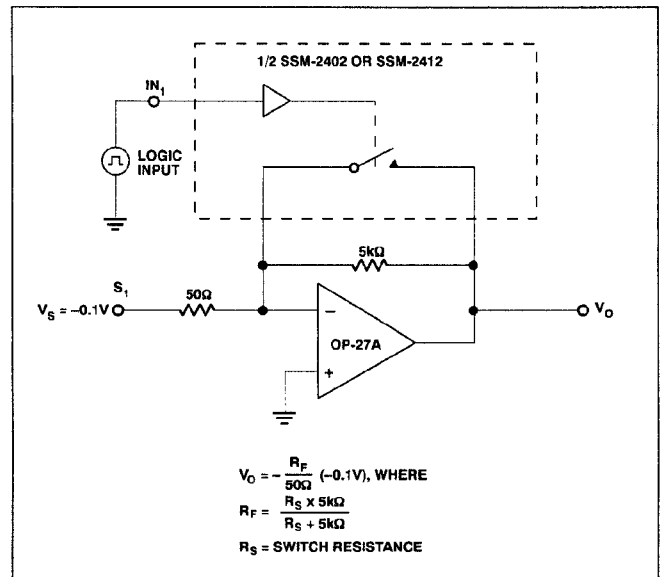

### "OFF" ISOLATION TEST CIRCUIT

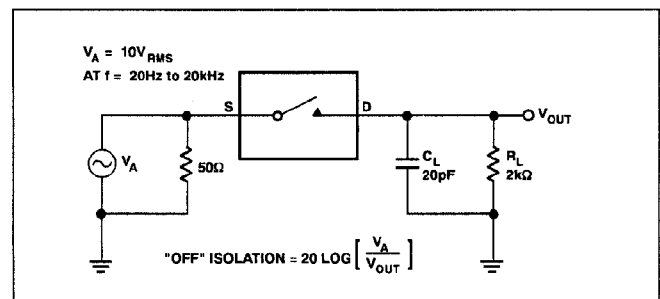

SWITCHING TIME TEST CIRCUIT

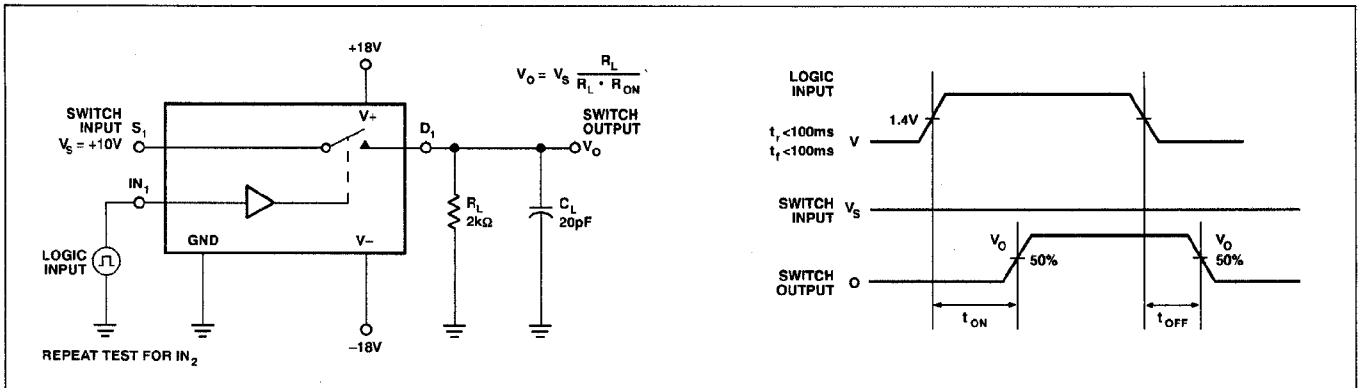

SIMPLIFIED SCHEMATIC

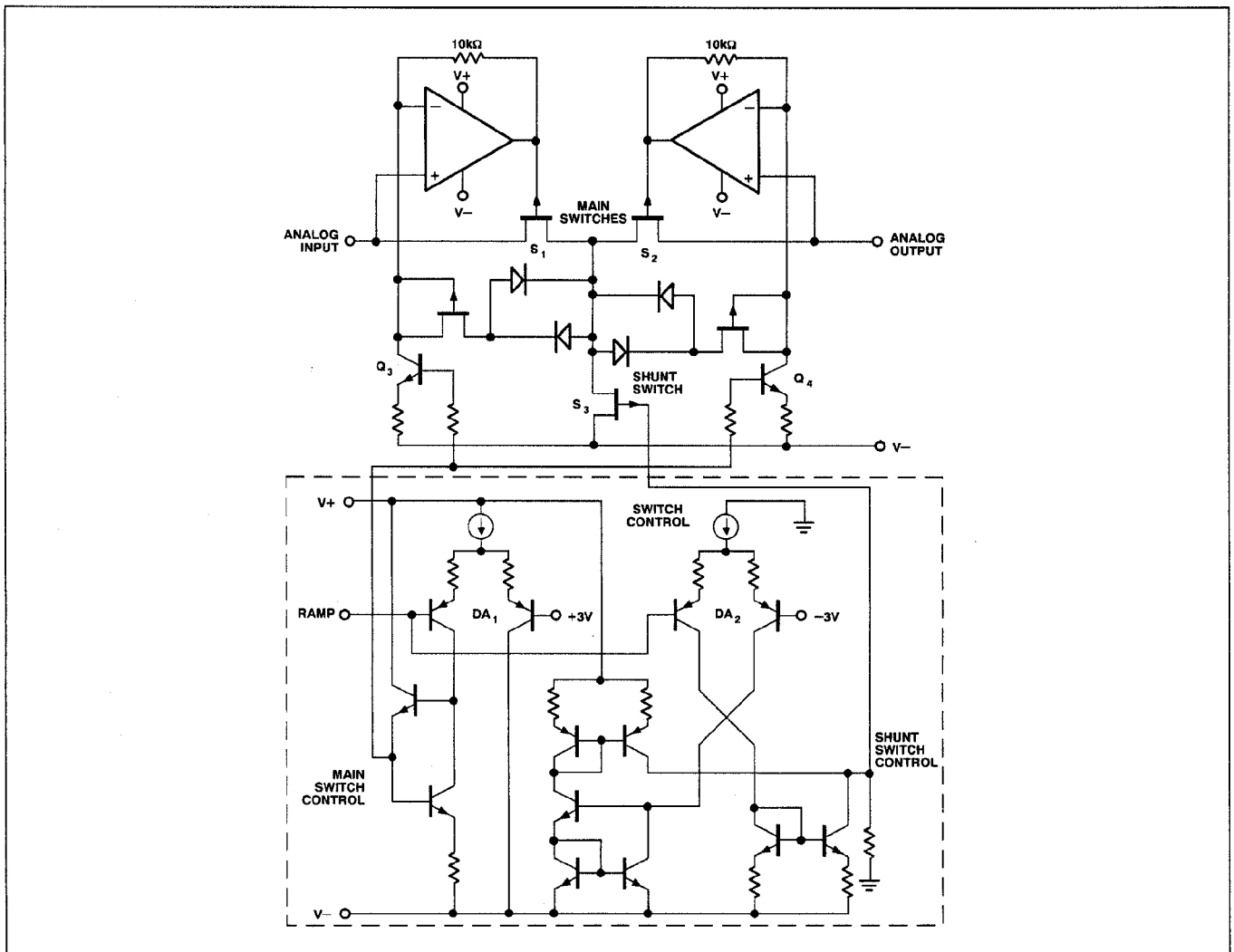

# SSM-2402/SSM-2412

## APPLICATIONS INFORMATION

### FUNCTIONAL SECTIONS

Each half of the SSM-2402/2412 are made up of three major functional blocks:

#### 1. "T" Switch

Consists of JFET switches  $S_1$  and  $S_2$  in series as the main switches and switch  $S_3$  as a shunt.

#### 2. Ramp Generator

Generates a ramp voltage on command of the Control Input (see Figure 1). A LOW-to-HIGH TTL input at Control Input initiates a ramp that goes from approximately  $-7V$  to  $+7V$  in 12ms. Conversely, a HIGH-to-LOW TTL transition at Control Input will cause a downward ramp from approximately  $+7V$  to  $-7V$  in 12ms for the SSM-2402, and 4ms for the SSM-2412. The Ramp Generator also supplies the  $+3V$  and  $-3V$  reference levels for Switch Control.

#### 3. Switch Control

The ramp from the Ramp Generator section is applied to two differential amplifiers ( $DA_1$  and  $DA_2$ ) in the Switch Control block. (See Simplified Schematic). One amplifier is referenced to  $-3V$  and the other is referenced to  $+3V$ . Switch Control Outputs are:

- **Main Switch Control** – Drives two 0.25mA current sources that control the inverting inputs of each op amp. When ON, the current sources cause a gate-to-source voltage of approximately 2.5V which is sufficient to turn off  $S_1$  and  $S_2$ . When the current sources from Main Switch Control are OFF, each op amp acts as a unity-gain follower ( $V_{GS} = 0$ ) and both switches ( $S_1$  and  $S_2$ ) will be ON.
- **Shunt Switch Control** – Controls the Shunt Switch of the "T" configuration.

### SWITCH OPERATION

Unlike conventional analog switches, the SSM-2402/2412 are designed to ramp on and off gradually over several milliseconds. The soft transition prevents popping or clicking in audio systems. Transients are minimized in active filters when the SSM-2402/2412 are used to switch component values.

To see how the SSM-2402/2412 switches work, first consider an OFF-to-ON transition. The Control Input is initially LOW and the Ramp Output is at approximately  $-7V$ . The Main Switch Control is HIGH which drives current sources  $Q_3$  and  $Q_4$  to 0.25mA each. These currents generate 2.5V gate-to-source back bias for each JFET switch ( $S_1$  and  $S_2$ ) which holds them OFF.

The Shunt Switch Control is negative which holds the shunt JFET  $S_3$  ON. Undesired feedthrough signals in the series JFET switches  $S_1$  and  $S_2$  are shunted to the negative supply rail through  $S_3$ .

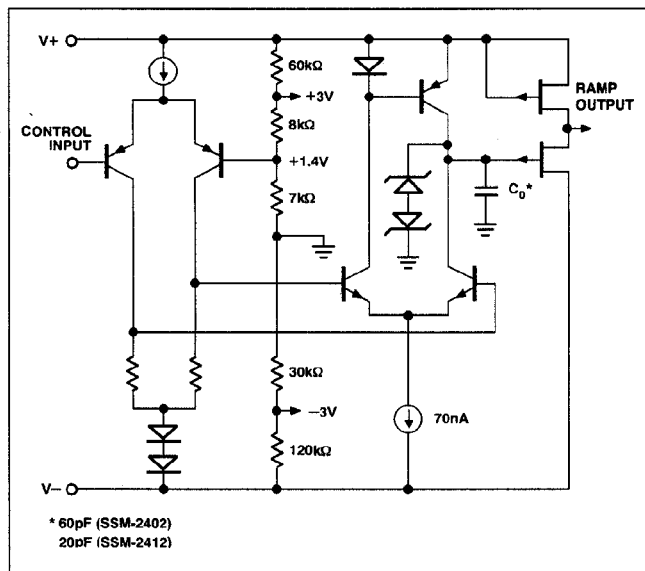

FIGURE 1: Ramp Generator

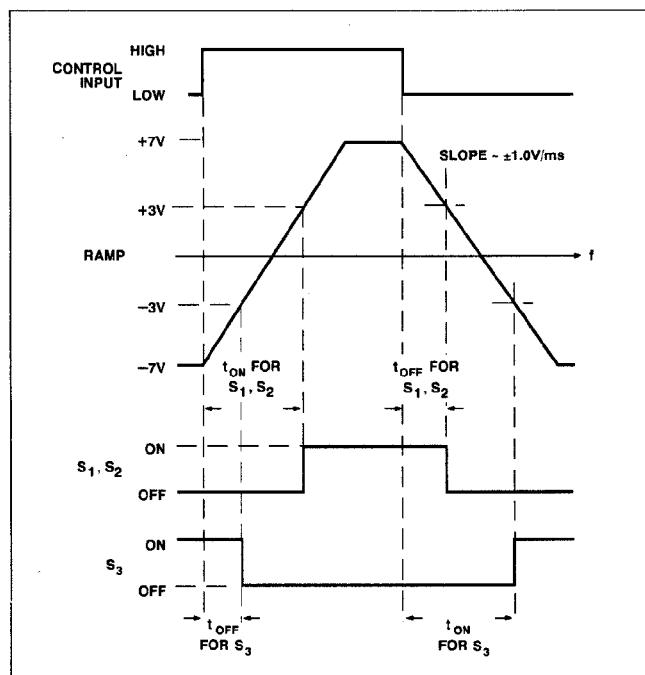

FIGURE 2: Switch Control



When the Control Input goes from LOW to HIGH, the Ramp Generator slews in the positive direction as shown in Figure 2. When the ramp goes more positive than  $-3V$ , the Shunt Switch Control is pulled positive by differential amplifier  $DA_2$  which thereby puts shunt switch  $S_3$  into the OFF state. Note that  $S_1$  and  $S_2$  are still OFF, so at this time all three switches in the "T" are OFF.

When the Ramp Output reaches  $+3V$ , and the drive for the Main Switch Control output is gated OFF by differential amplifier  $DA_1$ , current sources  $Q_3$  and  $Q_4$  go to the OFF state and the  $V_{GS}$  of each main switch goes to zero. The high-speed op amp followers provide essentially zero gate-to-source voltage over the full audio signal range; this in turn assures a constant low impedance in the ON state over the full audio signal range. Total time to turn on the SSM-2402 switch is approximately 10.0ms and 3.5ms for the SSM-2412.

In systems using a large number of separate switches, there are advantages to having faster switching into OFF state than into the ON state. Break-before-make can be maintained at the system level. To see how the SSM-2402/2412 guarantee break-before-make, consider the ON-to-OFF transition.

A Control Input LOW initiates the ON-to-OFF transition. The Ramp Generator integrates down from approximately  $+7V$  towards  $-7V$ . As the ramp goes through  $+3V$ , the comparator controlling the Main Switches ( $S_1$  and  $S_2$ ) goes HIGH and turns on current sources  $Q_3$  and  $Q_4$  which thereby puts  $S_1$  and  $S_2$  into the OFF state. At this time, all switches in the "T" are OFF. When the ramp integrates down to  $-3V$ , the Shunt Switch Control changes state and pulls shunt switch  $S_3$  into the ON state. This completes the ON-to-OFF transition;  $S_1$  and  $S_2$  are OFF, and  $S_3$  is ON to shunt away any undesired feedthrough. Note though that the ON-to-OFF time for main switches  $S_1$  and  $S_2$  is only the time interval required for the ramp to go from  $+7V$  to  $+3V$ , about 4ms for the SSM-2402, and 1.5ms for the SSM-2412. The time to turn on is about 2.5 times as long as the time to turn off.

The SSM-2402/2412 are much more than simple single solid-state switches. The "T" configuration provides superb OFF-isolation through shunting of feedthrough via shunt switch  $S_3$ . Break-before-make is inherent in the design. The ramp provides a controlled gating action that softens the ON/OFF transitions. Distortion is minimized by holding zero gate-to-source voltage for the two main FET switches,  $S_1$  and  $S_2$ , using the two op amp followers. Figure 3 shows a distortion comparison between the SSM-2402 and a typical CMOS switch. In summary, the SSM-2402/2412 are designed specifically for high-performance audio system usage.

#### OVERVOLTAGE PROTECTION

The SSM-2402/2412 are designed to guarantee correct operation with inputs of up to  $\pm 14.2V$  with  $\pm 18V$  supplies. The switch input should never be forced to go beyond the supply rails. In the OFF condition, if the inputs exceeds  $+14.2V$ , there is a risk of turning the respective input pass FET "ON." When the input voltage rises to within 3.8V of the positive supply, the op amp follower saturates and will not be able to maintain the full 2.5V of back bias on the gate-to-source junction. Under this condition, current will flow from the input through the shunt FET to the negative supply. This current is substantial, but is limited by the FET  $I_{DSS}$ . Although this current will not damage the device, there is a danger of also turning on the output pass FET, especially if the output is close to the negative rail.

This risk of signal "breakthrough" for inputs above  $+14.2V$  can be eliminated by using a source resistor of 100-500 $\Omega$  in series with the analog input to provide additional current limiting.

Near the negative supply, transistors  $Q_3$  and  $Q_4$  saturate and can no longer keep the switch OFF. Signal breakthrough cannot happen, but the danger here is latch-up via a path to  $V-$  through the shunt FET. Additional circuitry (not shown) has been incorporated to turn OFF the shunt FET under these conditions, and the potential for latch-up is thereby eliminated.

#### TYPICAL CONFIGURATION

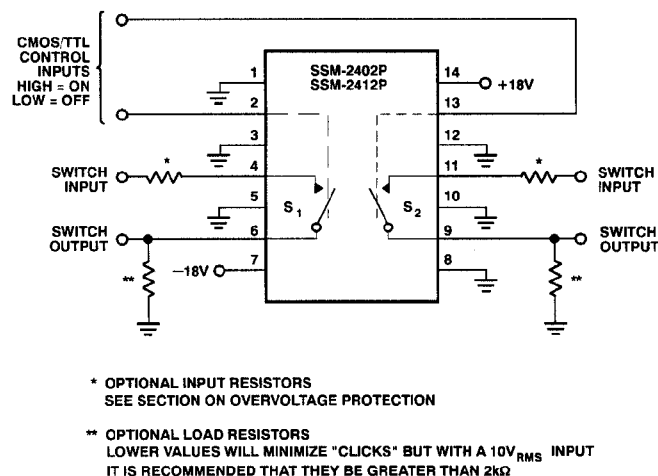

# SSM-2402/SSM-2412

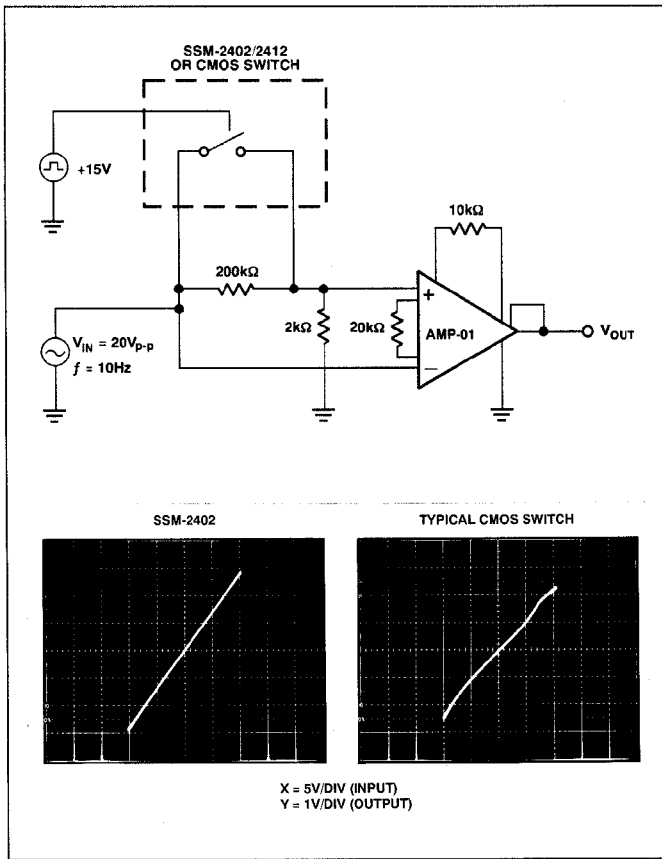

**FIGURE 3:** Comparison of the SSM-2402 and Typical CMOS Switch for Distortion

## DIGITALLY-CONTROLLED ATTENUATOR

Figure 4 shows the usual approach to digitally-controlled attenuation. With  $S_1$  closed, the signal passes unattenuated to the output. With  $S_1$  open and  $S_2$  closed, the signal is attenuated by  $R_1$  and  $R_2$ . The advantage of this configuration is that the attenuator current does not have to flow through the switches. The disadvantage is that the output is undefined during the switching period, which can be several milliseconds.

The low distortion characteristics of the SSM-2402/2412 enable the alternate arrangement of Figure 5 to be used. Now only one switch is required to change between two gains, and there is always a signal path to the output. Values for  $R_2$  will typically be in the low kilohm range.

For more gain steps and higher attenuation, the ladder arrangement of Figure 6 can be used. This enables a wide dynamic range to be achieved without the need for large value resistors, which would result in degradation of the noise performance.

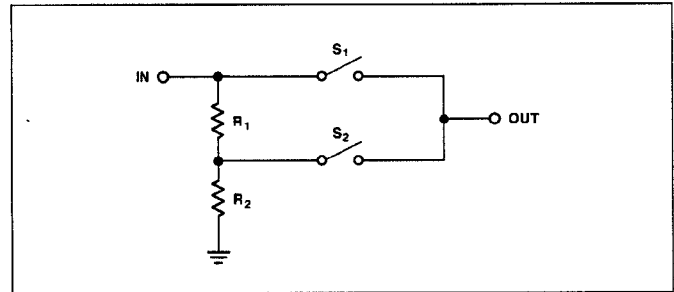

**FIGURE 4**

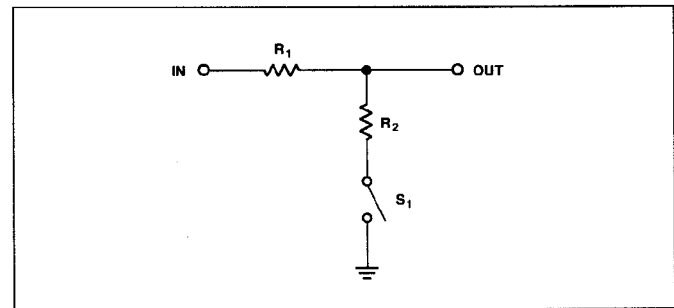

**FIGURE 5**

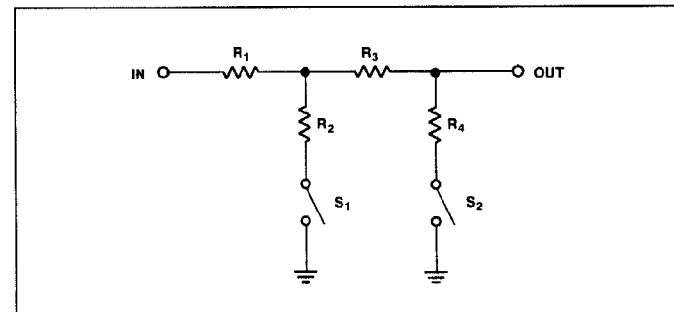

**FIGURE 6**

# SSM-2402/SSM-2412

## HIGH-PERFORMANCE STEREO ROUTING SWITCHER

The SSM-2402 Dual Audio Switch comprises the nucleus for this 16 channels-to-one high performance stereo audio routing switcher, which features negligible noise and low distortion over the frequency range of 20Hz to 20kHz. This performance is achieved even while driving 600Ω loads at signal levels up to +30dBu.

The SSM-2402 affords a much simplified electrical design and printed circuit board layout, along with reduced manufacturing cost, when compared with discrete JFET circuits of similar performance. The electrical performance of the design described is vastly superior to CMOS switch designs, which are more prone to failure resulting from electrical static discharge.

The switching control of the SSM-2402 may be activated by conventional mechanical switches or 5 volt TTL or CMOS logic circuits. The application shown utilizes a simple mechanical control switch for illustration purposes only. Many diverse X/Y control schemes, destination control, or computer controlled designs can be utilized.

The "T" configuration of the SSM-2402 switch provides excellent ON-OFF isolation. The SSM-2402 also features 7ms ramped turn on and 4ms ramped turn off for click-free switching. Additionally, the switch has a break-before-make switching sequence. Both features become significant in large audio switching systems where the audio path can pass through multiple switching elements. Such controlled switching is very important in large systems used in broadcast program switching or in production work.

The application circuit design also employs the SSM-2015 balanced input amplifier (Figure 7). The input impedance is high ( $\approx 100k\Omega$ ), balanced or unbalanced. The input circuit incorporates a single pole RFI filter with a cutoff frequency set at 145kHz. In addition, the input circuit attenuates the signal by 25dB and extends the common-mode input voltage range to  $\pm 98$  volts peak, with common-mode rejection greater than 70dB from 20Hz to 20kHz. The SSM-2015 is set to produce a 15dB gain. The signal drive level into the SSM-2402 switch is then +10dBu with a +20dBu input level and +14dBu peak, well within

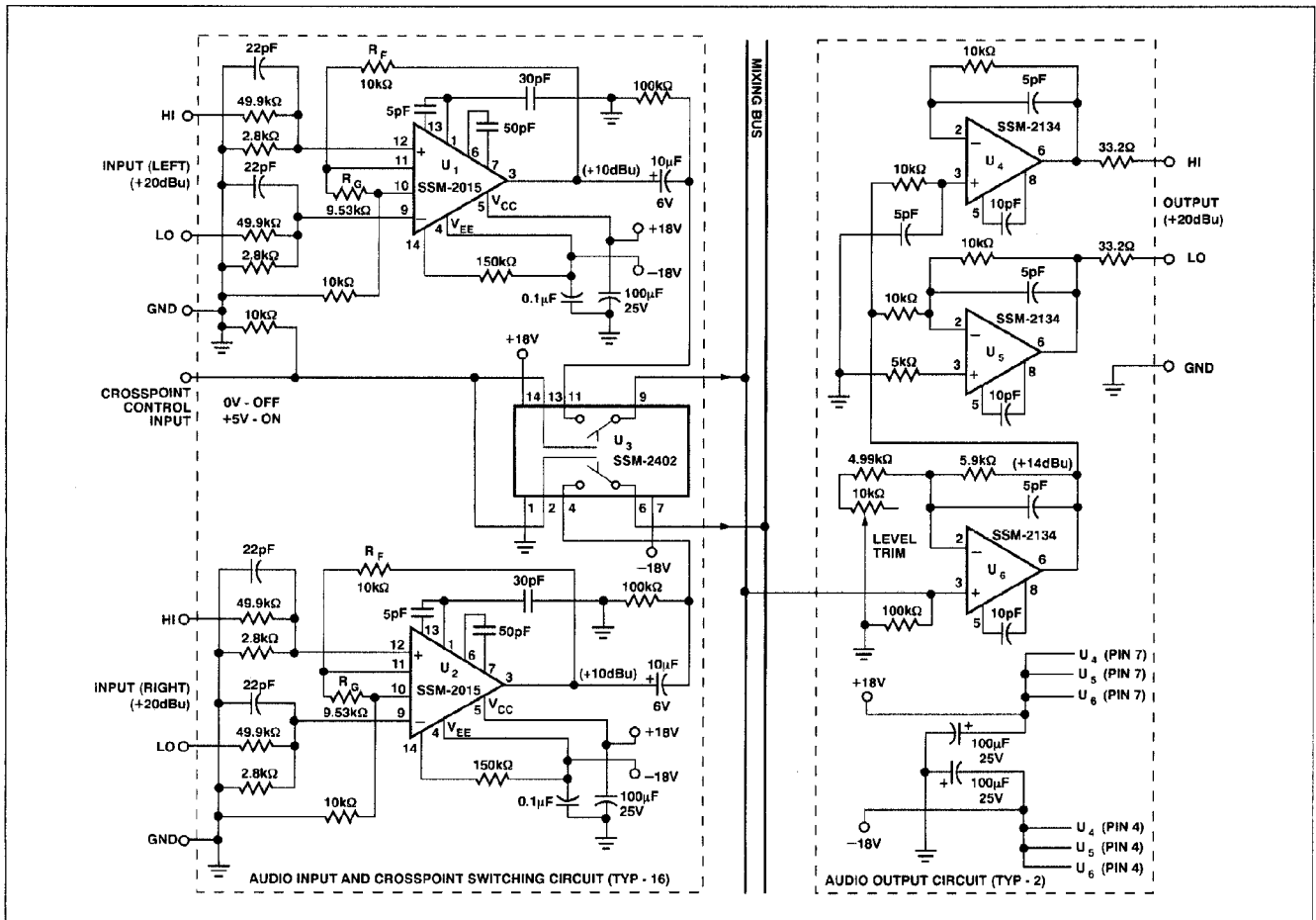

FIGURE 7: Switcher Schematic

# SSM-2402/SSM-2412

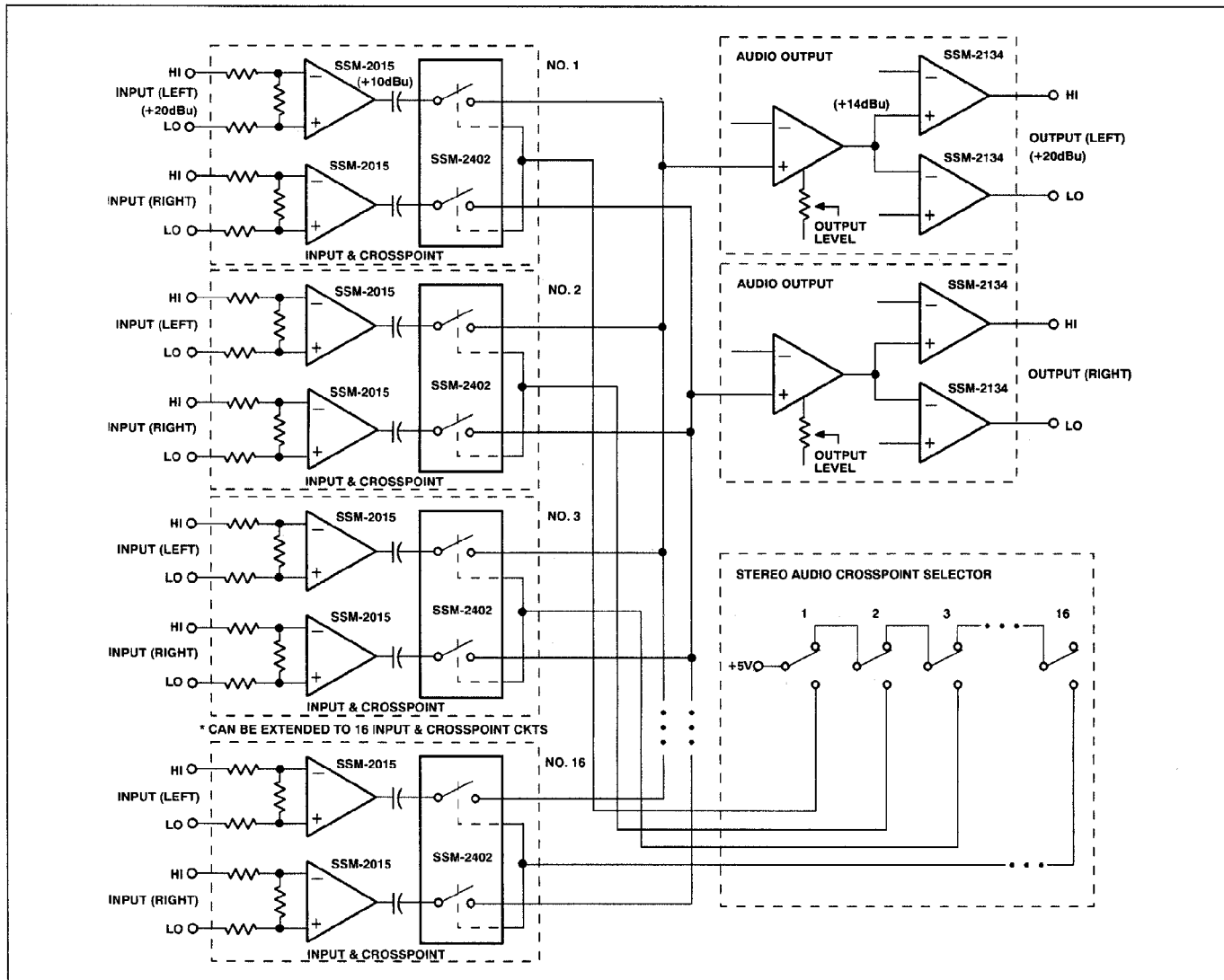

FIGURE 8: Switcher Functional Block Diagram

ideal operating range. Good signal-to-noise is maintained, with generous head-room available by electing to use  $\pm 18\text{VDC}$  power supply voltages.

The routing switcher bus carries high level unbalanced audio, but is driven with low impedance sources. With the output impedance of the SSM-2015 at virtually  $0\Omega$  and the SSM-2402 switch ON, resistance is typically  $60\Omega$ . Bus-to-bus crosstalk is exceptionally low. For example, assuming  $14\text{pF}$  coupling between buses and  $20\text{kHz}$  signal, the crosstalk (isolation) exceeds  $80\text{dB}$ . The  $14\text{pF}$  would be representative for the  $16 \times 1$  stereo design shown. Shielding of the buses with a printed circuit board ground plane and physically isolating the input and output circuits will reduce the crosstalk even further. The "T" configuration of the SSM-2402 switch virtually eliminates crosstalk between the various input signal sources.

The output amplifier incorporates a buffer amplifier that provides  $4\text{dB}$  of gain (nominally), with adjustable output level trim control. The buffer also isolates the switching bus from the balanced output amplifier circuit. The balanced output is designed to drive  $600\Omega$  loads and utilizes two SSM-2134 IC amplifiers. The differential design increases drive capability, yet increases the heat dissipation surface area, and keeps IC package temperature well within safe operating limits, even when driving  $600\Omega$  loads. The SSM-2134 is recommended due to its low noise, wide frequency response, and output drive current capabilities.

Overall performance of the  $16 \times 1$  stereo switcher is noteworthy. Input-to-output frequency response is flat to within  $1\text{dB}$  over a  $10\text{Hz}$  to  $50\text{kHz}$  band. Total harmonic distortion plus noise is less than  $0.03\%$ , from  $20\text{Hz}$  to  $20\text{kHz}$ . SMPTE intermodulation distortion is less than  $0.02\%$ . The use of  $\pm 18\text{VDC}$  power supplies produces a  $+30\text{dBm}$  clip level, even when driving  $600\Omega$  loads.

**TABLE 1:** Circuit Performance Specifications

Max Input Level	+30dBu
Input Impedance, Unbalanced	100k $\Omega$
Input Impedance, Balanced	200k $\Omega$
Common-Mode Rejection (20Hz to 20kHz)	>70dB
Common-Mode Voltage Limit	$\pm$ 98V Peak
Max Output Level	+30dBu/dBm
Output Impedance	67 $\Omega$
Gain Control Range	$\pm$ 2dB
Output Voltage Slew Rate	6V/ $\mu$ s
Frequency Response ( $\pm$ 0.05dB)	20Hz to 20kHz
Frequency Response ( $\pm$ 0.5dB)	10Hz to 50kHz
THD + Noise (20Hz to 20kHz, +8dBu)	0.005%
THD + Noise (20Hz to 20kHz, +24dBu)	0.03%
IMD (SMPTE 60Hz & 4kHz, 4:1, +24dBu)	0.02%
Crosstalk (20Hz to 20kHz)	>80dB
S/N Ratio @ 0dB Gain	135dB

