

P-Channel MOSFETs, the Best Choice for High-Side Switching

Historically, p-channel FETs were not considered as useful as their n-channel counterparts. The higher resistivity of p-type silicon, resulting from its lower carrier mobility, put it at a disadvantage compared to n-type silicon.

Getting n-type performance out of p-type FETs has meant larger area geometries with correspondingly higher inter-electrode capacitances. Consequently, a truly complementary pair—a p-channel and an n-channel device that match in *all* parameters—is impossible.

Yet, despite its shortcomings, the p-channel MOSFET performs a vital “high-side” switch task that the n-channel simply cannot equal.

Used as a high-side switch, a p-channel MOSFET in a totem-pole arrangement with an n-channel MOSFET will simulate a high-current, high-power CMOS (complementary MOS) arrangement. Although the p-channel MOSFET cannot complement the n-channel in both on-resistance and capacitance simultaneously, such combinations as the low-threshold p-channel TP0610 and the n-channel 2N7000 together offer outstanding performance as a complementary pair.

Circuit Applications

Switching Ground-Return Loads

The principal application of the p-channel, enhancement-mode MOSPOWER FET is in switching power (or voltage) to grounded (ground return) loads.

To drive the FET properly, the gate voltage must be referenced to its source. For enhancement-mode MOSFETs, this gate potential is of the same polarity as the MOSFET’s drain voltage. To turn on, the n-channel MOSFET requires a positive gate-source voltage, whereas the p-channel MOSFET requires a negative gate-source potential.

During switching, a MOSFET’s source voltage must remain fixed, as any variation will modulate the gate and thus adversely affect performance. Figure 1 shows this degradation by comparing n-channel and p-channel MOSFET high-side switching.

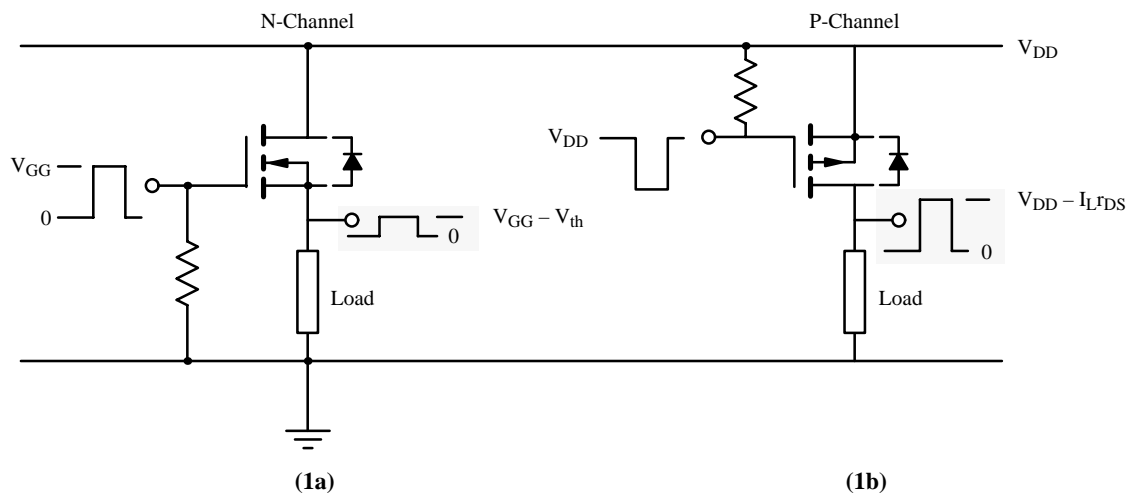

Figure 1. Comparing the Performance Between N-Channel and P-Channel Grounded-Load Switching

Updates to this app note may be obtained via facsimile by calling Siliconix FaxBack, 1-408-970-5600. Please request FaxBack document #70611.

AN804

If an n-channel, enhancement-mode MOSFET were switching a positive-polarity voltage to a grounded load, the output would be limited to $V_{GG} - V_{th}$.

The equations describing performance of the n-channel ground-switching MOSFET with a ground-reference gate drive are based on the relationship between V_{DD} and V_{GG} :

If $V_{DD} \geq V_{GG}$, then $V_O = V_{GG} - V_{th}$;

If $V_{DD} < V_{GG} - V_{th}$, then $V_O = V_{DD} - I_L r_{DS(on)}$.

Sustaining a more acceptable gain with an output in direct relation to V_{DD} would require an isolated gate drive referenced to the source (Figure 4). The dc bias option rectifies the pulse of ac from the transformer and stores a "+" voltage on the gate-to-source capacitance of the MOSFET. The RC determines the turn off time.

Bootstrapping the n-channel MOSFET (Figure 2) is satisfactory for short turn-on times of a few milliseconds. In this arrangement, both MOSFETs must have breakdown voltage specifications that match or exceed the supply voltage.

Using a p-channel MOSFET may place some severe restraints on the gate drive, since the gate must be close to V_{DD} (Figure 1b). To return gate control to a more acceptable logic format, add an n-channel MOSFET (Figure 3).

Using an n-channel MOSFET in this way simplifies the gate drive for a high-voltage, high-side, p-channel MOSFET. Placing a Zener diode between the gate and supply ensures that $V_{(BR)GSS}$ will not be exceeded. Again, both MOSFETs must withstand the full rail voltage.

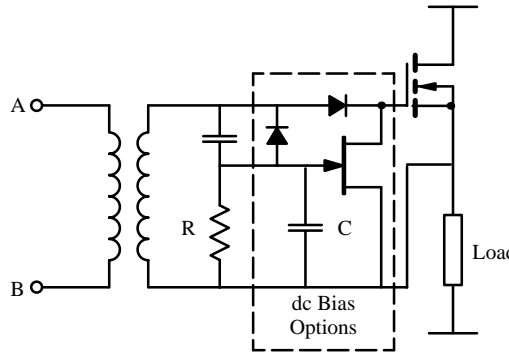

Figure 4. Floating Gate Drive

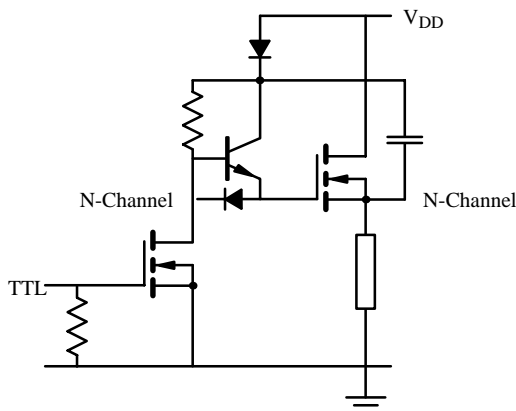

Figure 2. Bootstrapping for N-Channel Grounded-Load Switching

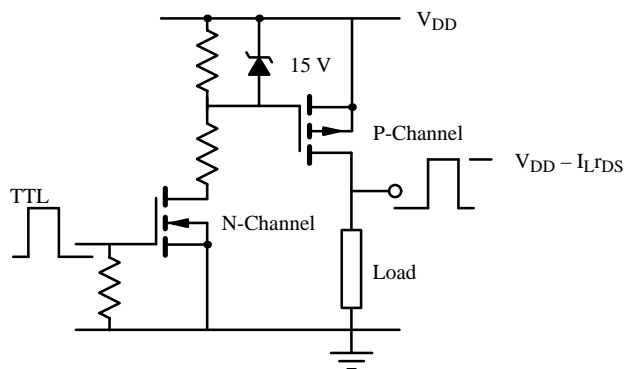

Figure 3. Using An N-Channel Level-Shifter Simplifies Driving From Logic

Half-Bridge (Totem Pole)

A high-side p-channel MOSFET and a low-side n-channel MOSFET tied with common drains (Figure 5) make a superb high-current “CMOS equivalent” switch. One fault common to such circuits has been the excessive crossover current during switching that may occur if the gate drive allows both MOSFETs to be on simultaneously.

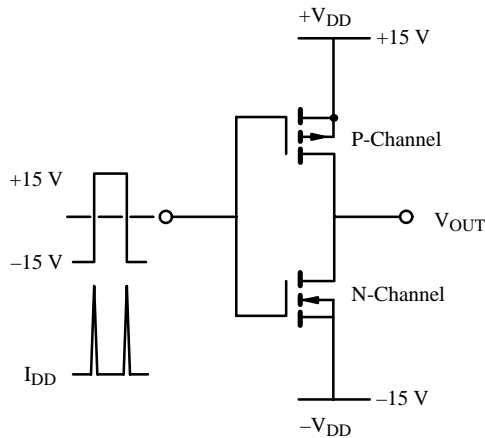

Figure 5. Low-Voltage Complementary MOSPOWER Array

Table 1. N- and P-Channel Dual MOSFETs in SO-8 Package for Output Stage

Part Number	V _{(BR)DSS} (V)	r _{DS Max} (Ω)	I _D (A)
Si9939DY	30/-30	0.05/0.1	3.5/-3.5
Si9942DY	20/-20	0.125/0.2	3/-2.5
Si9928DY	20/-20	0.05/0.11	5/-3.4

Properly driving the MOSFET gates can minimize unwanted crossover current at high supply voltages (both +V_{DD} and -V_{DD}) (Figure 6).

A resistively-coupled lower-power complementary pair offers extremely low crossover current when the output stage uses high-power MOSFETs. The Zener, Z1, and resistors, R1 and R3, act as a level shifter, properly driving the low-power MOSFETs. The Zener may be selected according to the equation

$$V_{ZENER} = 2 V_{DD} - |V_{th}|$$

where +V_{DD} = -V_{DD}

Whatever crossover current that might occur in the low-power drivers is dramatically reduced by the series resistor, R4. Additionally, driving the high-power complementary pair using this resistor divider scheme all but eliminates crossover current in this critical output driver. This increases both the driver's efficiency and its reliability.

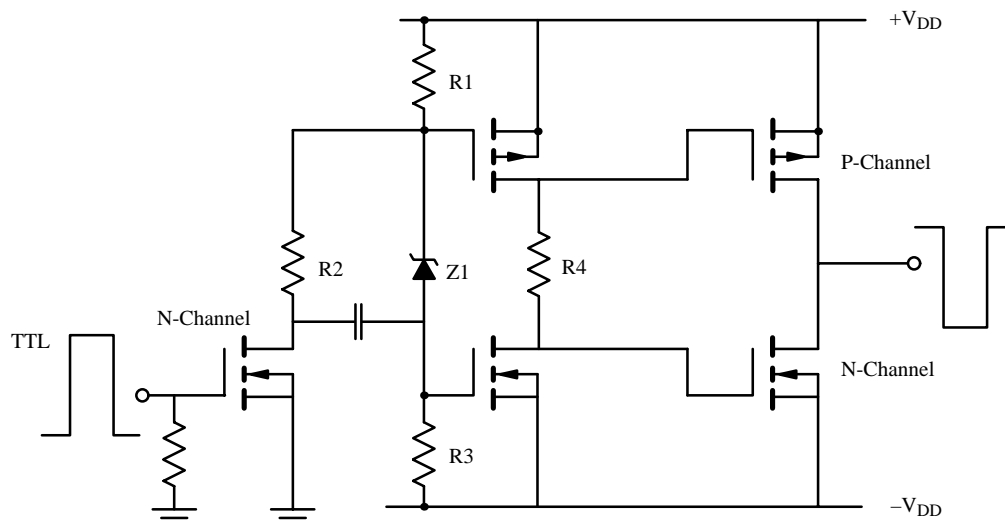

Figure 6. High-Voltage Complementary Pair Driven by Logic-Compatible MOSFET

AN804

Table 2. Popular Discrete N- and P-Channel MOSFETs for Input Driver Stages and Outputs

P-Channel Devices				N-Channel Devices			
Part Number	$V_{(BR)DSS}$ Min (V)	r_{DS} Max (Ω)	Package	Part Number	$V_{(BR)DSS}$ Min (V)	r_{DS} Max (Ω)	Package
VP0300L	-30	2.5	TO-226AA	VN0300L	30	1.2	TO-226AA
TP0610L	-60	10	TO-226AA	2N7000	60	5	TO-226AA
VP2020L	-200	20	TO-226AA	VN2010L	200	10	TO-226AA
TP0101T*	-12	0.65	TO-236	TN0200T*	20	0.4	TO-236
TP0610T*	-60	10	TO-236	2N7002*	60	7.5	TO-236

*Surface Mount Package